

EXPLOITING INTEGRATED PLANAR MAGNETICS

Introduction

By combining two or more magnetic elements into a single structure, magnetic integration allows more efficient use of a core's cross sectional area and reduces the need for core material.

In today's high-density switched-mode power supplies, transformers and inductors are the main contributors to their size, weight and volume. Magnetic integration is a solution where two or more magnetic elements are combined into a single structure. By proper phasing of the windings and the placement of an air gap in a specific location in the flux path, integration allows more efficient use of the cross sectional area of the transformer or inductor core, resulting in a reduced need for core material.

Power supply designers are becoming more interested in integrated magnetics, where both the transformer and the inductor, or two different inductors, can be integrated into a single structure. This integration process is proven technology but becomes a more attractive alternative as the size of converters becomes smaller. In any forward topology converter, transformers (Xfmrs) commonly are used as the energy transfer and isolation element, with inductors acting as the energy storage elements. Although these two elements possess different functionality, they can be integrated into a single structure either in a side-by-side or a top-to-bottom configuration.

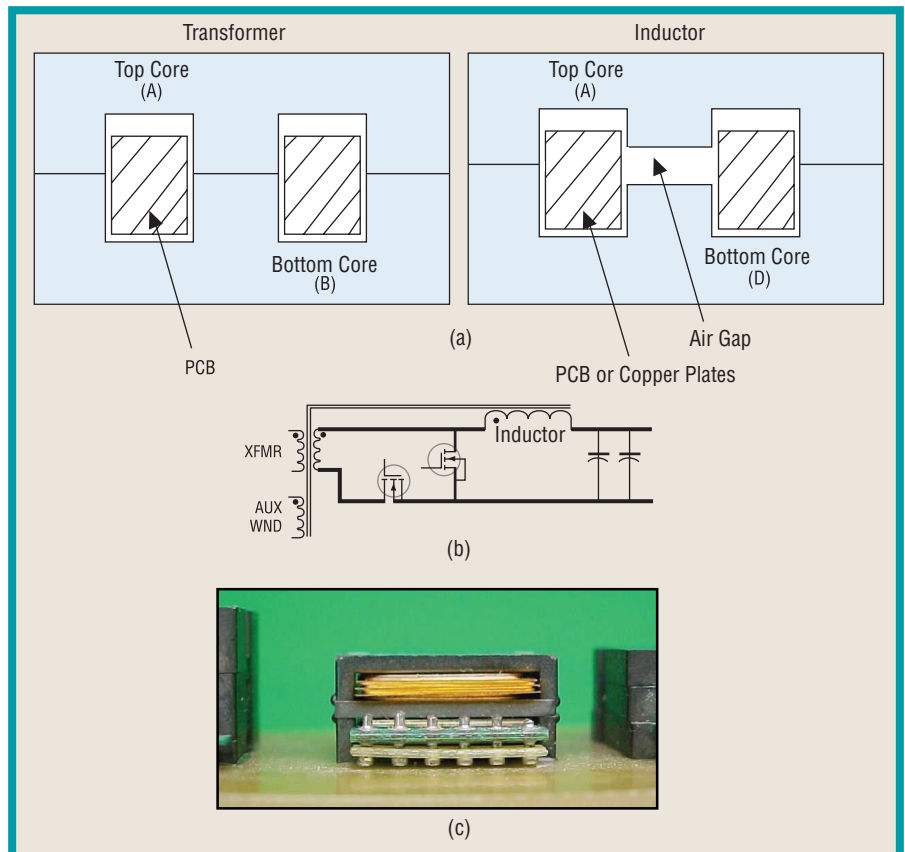

Fig. 1. Forward converter with integrated magnetics. Shown here are the cross sectional diagrams of the transformer and inductor when constructed separately (a), the forward converter schematic when magnetics are integrated (b) and a photo of the integrated planar magnetic device (c).

Advantages of Integrated Magnetics

Magnetics are the largest components in a power supply. The transformer is the largest and the second largest is the inductor. In a time where smaller is better, reducing the amount of real estate used by any component on a board is welcome. By combining the transformer and the inductor into one part, the amount of space the magnetics occupy is cut in half. An obvious benefit of smaller magnetics is the ability to reduce the size of the printed circuit board.

Another option, instead of reducing the board size, is to use the open area for something else, such as adding a heatsink for cooling. Thus, if you have a 100-W power supply and you add a heatsink in the newly added space, you can get 120 W from the same size power supply. Or, you can use two integrated magnetic

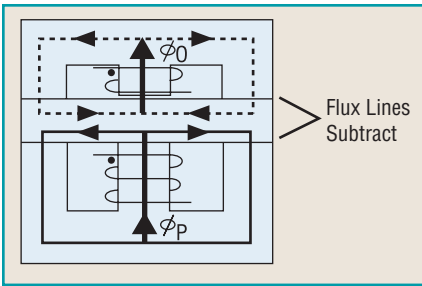

Fig. 2. Placing a high reluctance path (air gap) minimizes the magnetic interaction between transformer and inductor.

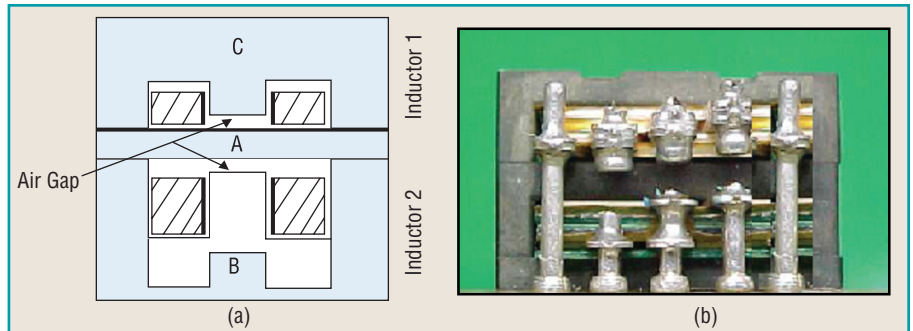

Fig. 3. Inductors 1 and 2 are integrated into a single structure as shown in the cross sectional diagram (a) and photo of the device (b).

components on the board and connect them so that primary windings could be in series and secondaries in parallel for increased output power. An integrated component allows for flexibility of board design.

Furthermore, combining the transformer and inductor provides additional benefits. These include reduced electromagnetic interference (EMI), increased operating efficiency of the power supply, a reduction in the materials needed to manufacture the integrated magnetics and overall reduced costs.

EMI is reduced using an integrated magnetic component because the shorter traces reduce the amount of area to radiate so there's less antenna effect. The layout is more organized with one localized emission, so the shield required is smaller and there is a smaller area of current radiation. In addition, operational efficiency is improved because the lower resistance in the shorter traces produces less heat. These shorter traces also exhibit lower voltage drops, which causes a better utilization of the duty cycle. Plus, flux cancellation in the core reduces the core losses.

A reduction in the materials being used in the power supply is another benefit. Each inductor and transformer has two core pieces. In the integrated component, there are three core pieces instead of four, because the components are stacked with a single layer between the parts. Twenty-five percent of cost is in the core material, so if you reduce the core material, the price reflects that. Reducing the size of the board also reduces cost.

How Integrated Magnetics are Configured

A typical forward converter with an auxiliary (AUX) winding has a transformer and inductor in two separate components. The forward converter with an integrated magnetic formed into a single construction uses a single structure for both the transformer and inductor to create the overall component. The xy footprint reduces almost in half while the height has to increase. The height will be a variable factor and depends on the number of watts needed, frequency of operation and the needed inductance. The wattage ranges from 20 W to 300 W.

Fig. 1 shows the cross sectional diagrams of the forward converter's transformer and inductor when they are built as separate components (part a). This figure also shows the schematic of the forward converter for the case where the transformer and inductor have been integrated (part b). To integrate the two magnetic elements into a single structure, the core (D) in the cross sectional diagram (part a) is eliminated and the top portion of the transformer core (A) provides a common flux path for both magnetic elements. A photo of the actual integrated magnetic device is shown in Fig. 1, part c. Integration is achieved by proper phasing of the windings in both transformer and inductor in order to subtract the magnetic flux in the common path (core piece A).

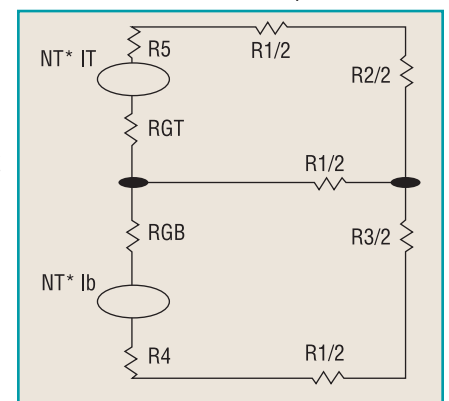

Fig. 4. Shown here is the simplified model for the reluctance circuit of a dual output inductor.

To minimize the magnetic interaction between both transformer and inductor, a high reluctance path (air gap) can be placed so the flux lines for each element stay in their original path, with the exception of the common

path where flux lines subtract, as seen in Fig. 2. To calculate the high reluctance of the air gap, the formula $R_{gap} = L_{gap} / \mu_{air}$ (center leg A in Fig. 3) can be used.

This high reluctance forces the flux caused by the primary winding (F_p) to stay within the transformer segment and minimizes the magnetic interaction between the transformer and the inductor. Thus, both elements function independently and can be put into a single assembly without any compromise in switched mode power supply (SMPS) characteristics.

This method also can be used to combine two individual output inductors in a multiple output converter into a single structure, thereby reducing the number of needed core pieces from the usual four to just three. Examples are a typical forward converter with two output voltages and two separate output inductors, and inductors with conventional separate constructions (Fig. 3).

In designing integrated magnetics into a power supply, there are three basic guidelines the designer must remember:

1. Due to the subtraction or addition of flux lines, the flux density distribution can be different in each core section. The designer needs to pay attention to the flux density distribution at each core section and calculate the needed cross sectional of each section accordingly.
2. Proper phasing of each winding causes the desired direction of flux lines in order to achieve flux subtraction.
3. Placement of the air gap (high reluctance) at a specific area minimizes magnetic interaction among the independent magnetic elements. This air gap placement causes the flux from one element to have a zero net effect on the other element.

The following is an example of a dual output inductor and its defined electrical circuit equivalent. For simplicity, and to better understand the modeling steps, we consider an ideal model (Fig.4).

The reluctance model can be changed to the permeance model, which is an inverse of reluctance. Using the duality theorem, we come up with the permeance circuit model by rotating the current in the simplified reluctance model by 90 degrees clockwise. We can also mirror the circuit for the permeance model with reversed current direction.

Now that we have the permeance model of our integrated dual inductor, we can scale permeance by the square of turns for the selected winding and then replace the scaled permeance by the inductance (L). The formula for that is permeance (P) times the number of turns (N) squared: $L = (N^2)*P$. We also will replace flux linkages by voltage sources: $v = N*(F/T) = N*(F/T)$ (Fig. 5).

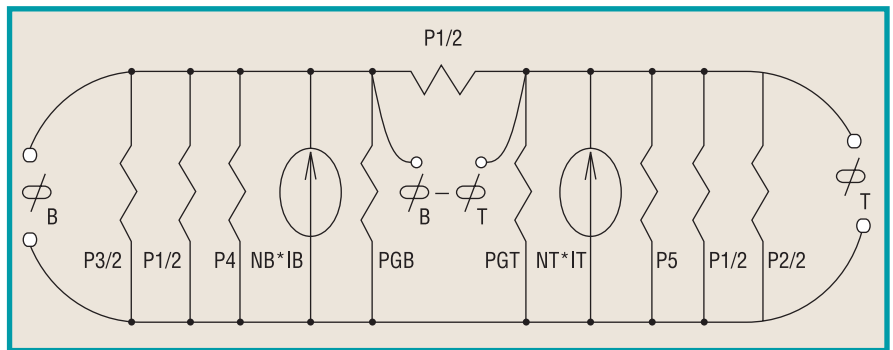

Fig. 5. The permeance model shown here is the inverse or mirror circuit of the reluctance model shown in Fig. 4. Note the reversed current direction.

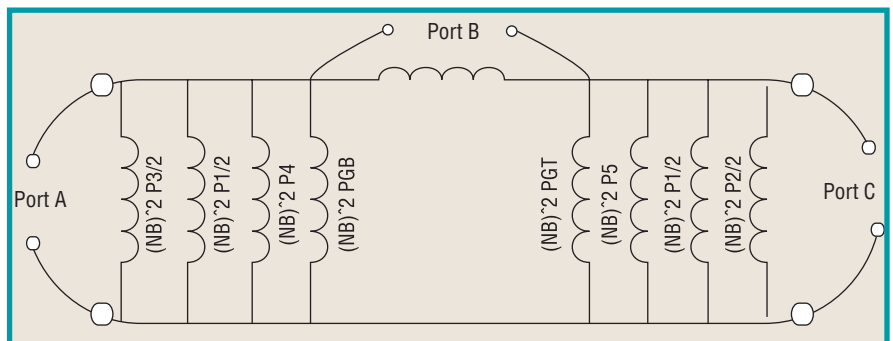

Fig. 6. The final inductance model for dual inductor is based on three equations: PORT B = $NB*(F_B - F_T)$, PORT A = $F_B.NB$ and PORT C = $F_T.NT$.

Fig. 6 shows the final inductance model for our dual inductor. This model is based on the following equations: PORT B = $NB.(F_B - F_T)$ PORT A = $F_B.NB$ PORT C = $F_T.NT$

This model demonstrates the inductance of the air gap is in parallel to the inductance established by the core material, so that the air gap inductance will be the dominant factor.

Keep in mind that in real magnetic elements, the leakage fluxes that create other paths need to be added into the model. While this makes the model more complex, it also is more realistic. The integrated magnetic is one where the flux distribution could be different in each section of the core and should be designed accordingly so no individual section will saturate.

Integrated magnetics can be used in any power supply dealing with forward or any other types of different topologies. It is applicable for any wattage, but is more practical in the range of 50 W to 200 W where size is critical. Because the platform is standard, it provides integration without having to reconfigure the design.

Applications for Integrated Magnetics

Integrated magnetics work especially well in applications using planar transformers. The engineer can benefit from the advantages of a planar transformer without worrying about changing the board when there is a change in the number of turns. That's because the transformers used in the integrated magnetics consist of 45 part options that can be arranged in 293 different winding configurations. Adding a primary auxiliary winding or a small gap to the transformer expands the number of possible configurations to more than 1000.

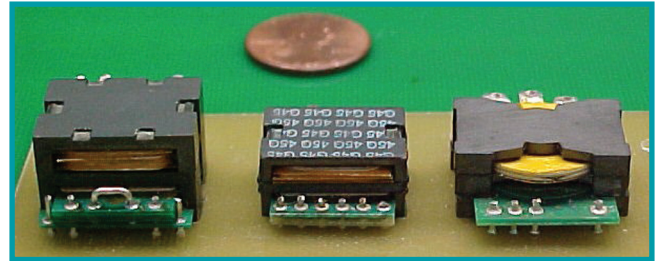

With an emphasis in designing high-density switched mode power supplies to get the most power and efficiency in the least amount of space, managing thermal issues, and reducing costs, an excellent solution is the integrated magnetic component. Transforming the transformer and inductor into one compact component designed to fit the footprint of common platforms gives the design engineer flexibility to reduce board size or pack more functionality into existing board space. Examples of inductors and transformers integrated into a single structure are shown in Fig.7.

Patented: US Patent 6,420,953

Written By: By Majid Dadafshar & John Gallagher