

features

- Various types of standard circuits in different sizes and power are available. (Seated height 0.20" (5.08mm), 0.26" (6.5mm), 0.42" (10.7mm) Max.)
- Higher temperature soldering of the leads prevents terminals from loosening during board assembly
- For automatic insertion machines, stick magazines (the tip of lead terminal is cut to a V shape) and taping packages (TBA: All leads taping, TPA, TUA: 3 leads taping) are applicable.
- Products with lead-free terminations meet EU RoHS requirements. EU RoHS regulation is not intended for Pb-glass contained in electrode, resistor element and glass.

dimensions and construction

(See table below)

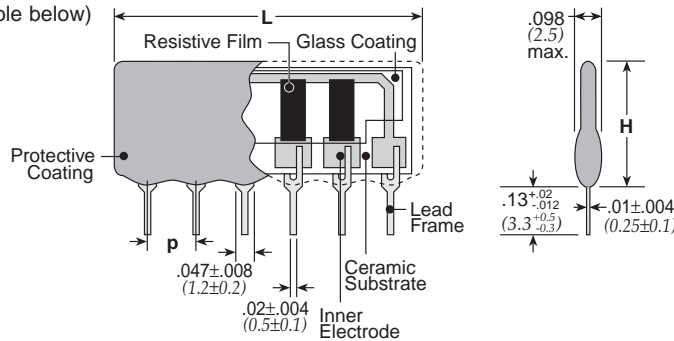

leaded resistors

Size Code		Number of Pins														Dimen. in. (mm)		
		3	4	5	6	7	8	9	10	11	12	13	14	15	16	H max.	p	
RKL	W	L	8.20	10.16	12.70	15.24	17.78	20.32	22.86	25.40	27.94	30.48	—	—	—	—	.200 (5.08)	.100±.008 (2.54±0.2)
		B,A,R circuit	250	375	500	625	750	875	1000	1050	1150	1250	—	—	—	—		
		C,T,E circuit	—	—	500	—	750	—	1000	—	1150	—	—	—	—	—		
		D circuit	—	—	375	500	625	750	875	1000	1125	1250	—	—	—	—		
		S Circuit	—	400	—	600	—	800	—	1000	—	1200	—	—	—	—		
RKC (2.54 pitch)	W	L	8.20	10.8	13.2	15.8	18.3	20.9	23.4	25.9	28.5	31.0	33.6	36.1	38.7	41.3	.256 (6.5)	.100±.008 (2.54±0.2)
		B,A,R circuit	250	375	500	625	750	875	1000	1050	1150	1250	1350	1450	1500	1550		
		C,T,E circuit	—	—	500	—	750	—	1000	—	1150	—	1350	—	—	—		
		D circuit	—	—	375	500	625	750	875	1000	1125	1250	1350	1450	—	—		
		S Circuit	—	500	—	750	—	1000	—	1050	—	1250	—	1450	—	—		
RKH	W	L	—	10.8	13.3	15.8	18.3	20.9	23.4	25.9	28.5	31.0	33.6	—	—	—	.421 (10.7)	.100±.008 (2.54±0.2)
		B,A,R circuit	—	525	700	875	1050	1250	1400	1500	1600	1700	1800	—	—	—		
		C,T,E circuit	—	—	700	—	1050	—	1400	—	1600	—	1800	—	—	—		
		D circuit	—	—	700	875	1050	1250	1400	1500	1600	1700	—	—	—	—		
		S Circuit	—	500	—	1050	—	1400	—	1500	—	1700	—	—	—	—		
RKC (1.8 pitch)	L	—	10.2	10.8	12.7	15.5	15.8	17.8	20.4	20.9	23.5	25.4	28.5	—	—	.256 (6.5)	.071±.006 (1.8±0.15)	
	W	—	300	400	500	580	650	720	760	820	850	880	900	—	—			

L= L dimension (mm) max. W= Wattage/Package (mW) max.

ordering information

RKC	8	B	S ¹	D	STP	103	F
Type	Number of Resistors	Circuit Symbol	1.8mm Symbol	Termination Material	Packaging	Nominal Resistance	Tolerance
RKC RKH RKL	3 - 16	B, S, C, D, A, T, E, R RKC: L, K	RKC only	D: SnAgCu (Other termination styles available, contact factory for options)	STP, STB TPA: (4-9 pins) or TUA (10 pins) taping (3 leads) TBA: (4-10 pins) taping (all leads)	2 significant figures + 1 multiplier for ±2% & ±5% 3 significant figures + 1 multiplier for ±1% R1/R2 3 digits/3 digits	F: ±1% G: ±2% J: ±5% R circuit: ±2%, ±5% only

For further information on packaging, please refer to Appendix C.

¹ The symbol "S" showing 1.8 pitch is added to the type designation after the circuit symbol.

Specifications given herein may be changed at any time without prior notice. Please confirm technical specifications before you order and/or use.

10/03/23

circuit schematics

B circuit

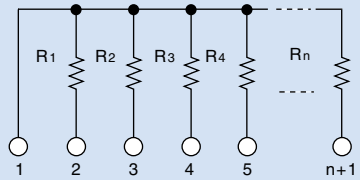

$R1=R2=R3=R4=...=Rn$
n: number of elements
Example: RKC8B 103 J
RKL8B 472 J
RKH8B 332 J

S circuit

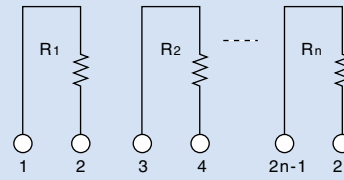

$R1=R2=...=Rn$
n: number of elements
Example: RKC4S 103 J
RKL4S 472 J
RKH4S 332 J

C circuit

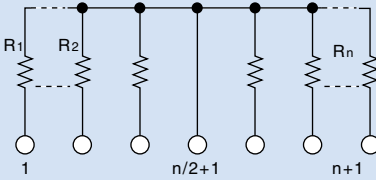

$R1=R2=R3=R4=...=Rn$
n: number of elements
Example: RKC8C 103 J
RKL8C 472 J
RKH8C 332 J

D circuit

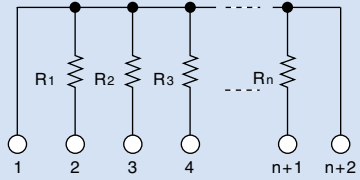

$R1=R2=R3=...=Rn$
n: number of elements
Example: RKC8D 103 J
RKL8D 472 J
RKH8D 332 J

A circuit

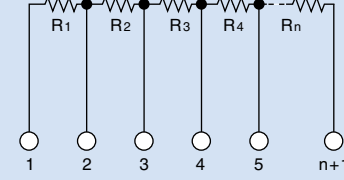

$R1=R2=R3=R4=...=Rn$
n: number of elements
Example: RKC8A 103 J
RKL8A 472 J
RKH8A 332 J

T circuit

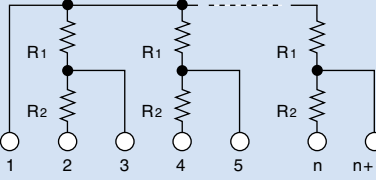

$R1=R2$ or $R1 \neq R2$
n: number of elements
Example: RKC8T 103/103 J
RKL8T 103/103 J
RKH8T 103/103 J

E circuit

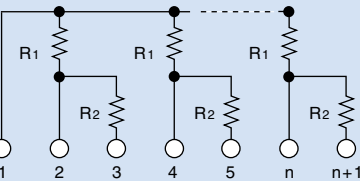

$R1=R2$ or $R1 \neq R2$
n: number of elements
Example: RKC8E 103/103 J
RKL8E 103/103 J
RKH8E 103/103 J

R circuit

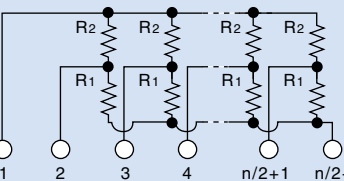

$R1=R2$ or $R1 \neq R2$
n: number of elements
Example: RKC16R 331/471 J
RKL16R 331/471 J
RKH16R 331/471 J

L circuit

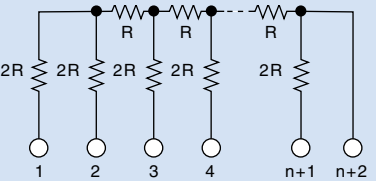

n: number of elements
Example: RKC5L 253

K circuit

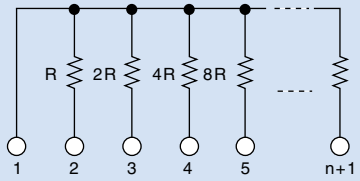

n: number of elements
Example: RKC4K 102

Example of custom circuit

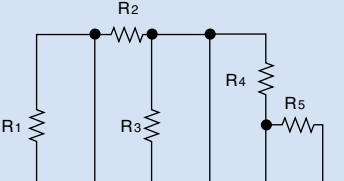

Example of custom circuit

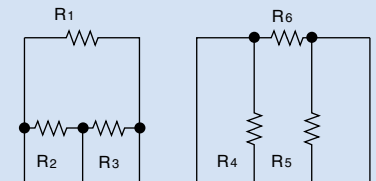

applications and ratings

Part Designation	Circuit Symbol	Number of Pins	Power Rating/Element	T.C.R. (ppm/°C) Max.	Resistance Range (Ω)	Resistance Tolerance	Maximum Working Voltage	Rated Ambient Temperature	Operating Temperature Range	
RKC	B	3-16	125mW	±200	22-2.2M (E24)	F: ±1% G: ±2% J: ±5%	200V	+70°C	-55°C to +155°C	
	C	5-13								
	D	5-14								
	A	4-14								
	T	5-13								
	E	5-13	250mW							
	S	4-14	125mW		100-100k (E24)	G: ±2% J: ±5%				
	L	6-10	20mW		±200	R=2.5k, 5k 10k, 25k 50k, 100k	±1/2LSB (Bit Error)	20V		+70°C
	K	5-9	40mW			R1(MSB):100 Min Rn(LSB):1M Max	±1/2LSB (Bit Error)			
RKL	B	3-12	125mW	±200	22-1M (E24)	F: ±1% G: ±2% J: ±5%	100V	+70°C	-55°C to +125°C	
	C	5-11								
	D	5-12								
	A	3-12								
	T	5-11								
	E	5-11	200mW							
	S	4-12	125mW		100-100k (E24)	G: ±2% J: ±5%				
RKH	B	4-13	250mW	±200	56-2.2M (E24)	F: ±1% G: ±2% J: ±5%	250V	+70°C	-55°C to +155°C	
	C	5-13								
	D	5-12								
	A	4-12								
	T	5-13								
	E	5-13	500mW							
	S	4-12	250mW		100-100k (E24)	G: ±2% J: ±5%				
M-	RKL	3-12	100mW	±100 ±150 ±200	10-10M	±0.5% ±1% ±2% ±5%	100V	+70°C	-55°C to +125°C	
	RKC (1.8 pitch)	4-14	125mW				50V			
	RKC (2.54 pitch)	3-16	250mW				200V			
	RKH	4-13	500mW				250V			

Rated voltage = $\sqrt{\text{power rating} \times \text{resistance value}}$ or max. working voltage, whichever is lower.

leaded resistors

weight (g/1000 pcs)

	Number of Pins						
	3	4	5	6	7	8	9
RKL	147	185	228	271	314	357	400
RKC	160	217	273	330	387	444	501
RKH	—	416	511	606	701	796	891

	Number of Pins						
	10	11	12	13	14	15	16
RKL	443	486	529	—	—	—	—
RKC	558	615	672	728	785	842	893
RKH	986	1081	1176	1271	—	—	—

environmental applications

Derating Curve

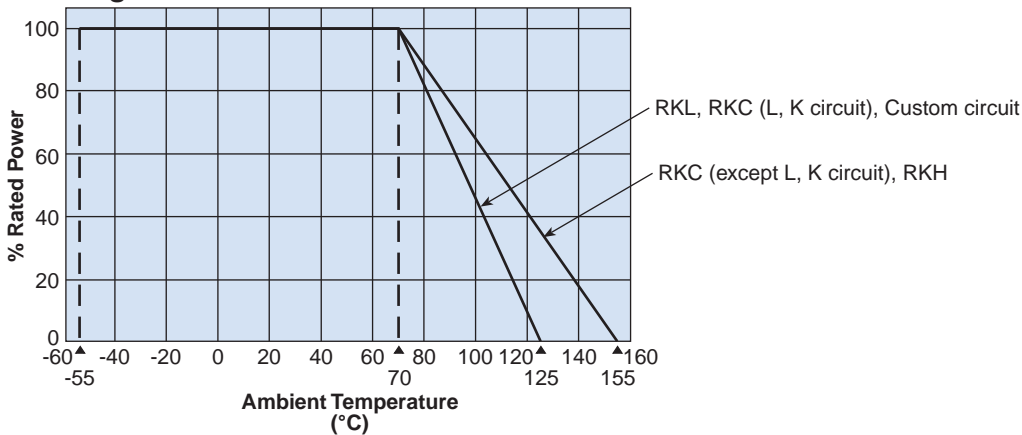

For resistors operated at an ambient temperature of 70°C or above, a power rating shall be derated in accordance with the above derating curve.

Performance Characteristics

Parameter	Requirement $\Delta R \pm(\%+0.05\Omega)$		Test Method
	Limit	Typical	
Resistance	Within specified tolerance	—	25°C
T.C.R.	Within specified T.C.R.	—	+25°C/-55°C, +25°C/+125°C (RKL) +25°C/-55°C, +25°C/+155°C (RKC, RKH)
Overload (Short time)	$\pm 0.5\%$	$\pm 0.25\%$	Rated voltage x 2.5 for 5 seconds
Resistance to Solder Heat	$\pm 0.5\%$	$\pm 0.25\%$	260°C \pm 5°C, 10 seconds \pm 1 second
Temperature Cycling	$\pm 0.5\%$	$\pm 0.25\%$	-40°C (30 minutes), +85°C (30 minutes), 5 cycles
Moisture Resistance	$\pm 2.0\%$	$\pm 1.0\%$	40°C \pm 2°C, 90 - 95% RH, 1000 hours, 1.5 hr ON, 0.5 hr OFF cycle
Endurance at 70°C	$\pm 2.0\%$	$\pm 1.0\%$	70°C \pm 2°C, 1000 hours, 1.5 hr ON, 0.5 hr OFF cycle