

A Microwave Tuning Element Applications Guide

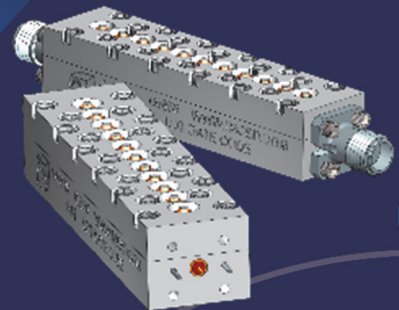

Operating in the microwave through millimeter wave (mmWave) bands, Knowles Johanson brand Microwave Tuning elements are specifically designed for tuning microwave circuits such as filters, oscillators, delay lines, multiplexers, and dielectric resonant structures. In this application note, we discuss the advantages of working with tuning elements versus using a “hardware store” solution, typical applications that can greatly benefit from the use of tuning elements, and the many solutions we offer to help meet all your tuning needs.

A Microwave Tuning Element Applications Guide



Johanson Microwave Tuning Elements from Knowles Precision Devices are specially designed devices for tuning microwave circuits such as filters, oscillators, delay lines, multiplexers, and dielectric resonant structures. Generally, Johanson Tuning Elements consist of a mounting bushing with an integral tuning rotor and adjusting the rotor changes the capacitive loading between the ground plane and the active regions of the circuit. Operating in the microwave through mmWave bands, Johanson Microwave Tuning elements are available in three basic material options – metallic, dielectric, and resistive.

THE BENEFITS OF JOHANSON MICROWAVE TUNING ELEMENTS

The primary advantages of Johanson Microwave Tuning Elements over using standard screws and nuts include the drastic reduction in technician tuning time, lower associated tuning losses, and increased tuning resolution. Using Johanson Microwave Tuning Elements properly also allows for the relaxation of costly circuit mechanical tolerances. Additionally, specifications defining the exact parameters of devices, such as step recovery diodes, varactors, transistors, and dielectric resonant materials, may also be

broadened, resulting in increased cost effectiveness.

Prior to the introduction of Johanson Microwave Tuning Elements, microwave circuit designers were burdened with the frustrating task of selecting from a makeshift conglomeration of "hardware store" nuts and bolts to tune precision microwave circuitry. Non-precision threads, lack of tolerance, finish irregularities with associated binding, and locking problems drastically increased the installed cost of seemingly inexpensive nuts and bolts hardware. This is because once a screw is adjusted, it needs to be secured in place by jam nuts, perpendicular set screws, or epoxy – which all require additional labor and introduce the probability of disturbing the initial adjustment and severely limiting retune capabilities.

In sharp contrast, Johanson Microwave Tuning Elements have a self-locking constant torque drive mechanism. This mechanism does not require an external locking device and permits one-handed tuning with virtually no dynamic tuning noise that could otherwise imperil associated solid-state devices under "power on" conditions. This self-locking feature, coupled with tuning resolutions up to 108 threads per inch, assures unparalleled

control over the most critical and complex circuit tuning adjustments. In many instances, using Johanson Tuning Elements has cut technician tuning times in half.

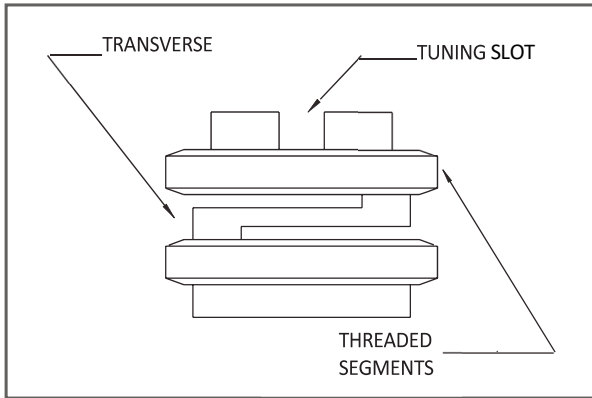

Figure 1: A schematic of the torque mechanism of a tuning rotor

In Figure 1, you can see that the rotor consists of two threaded segments coupled together by the spring effect of two transverse slots, which are axially compressed to affect a predetermined pitch distance offset relative to each threaded segment. This offset generates a dynamic tension between the threaded segments resulting in a constant contact, constant torque mechanism that is also self-locking.

TYPICAL APPLICATIONS

Generally, applications for microwave tuning elements are divided into the following three categories:

- Filters
- Oscillators
- Impedance transformers

The next part of this application note explores more details on the benefits of using tuning

elements for each of these applications.

FILTERS

Whether you are working with a cavity, coaxial cavity, interdigital, or combine filter, the filter will consist of resonant members with design inductance that must resonate with a predetermined capacity to satisfy the initial design parameters. As a result, the inherent variations in fabrication and assembly tolerances usually demand some type of adjustable compensation in the form of a shunt capacitance. This shunt capacitance must be located at the "open," or ungrounded, end of the resonator structure.

Relative to the resonator axis, the tuning element may be positioned as follows (see Figure 2):

- "Head on" to the resonator rod
- Perpendicular to the resonator rod
- Coaxially within the resonator rod
- Suspended into a cavity or waveguide

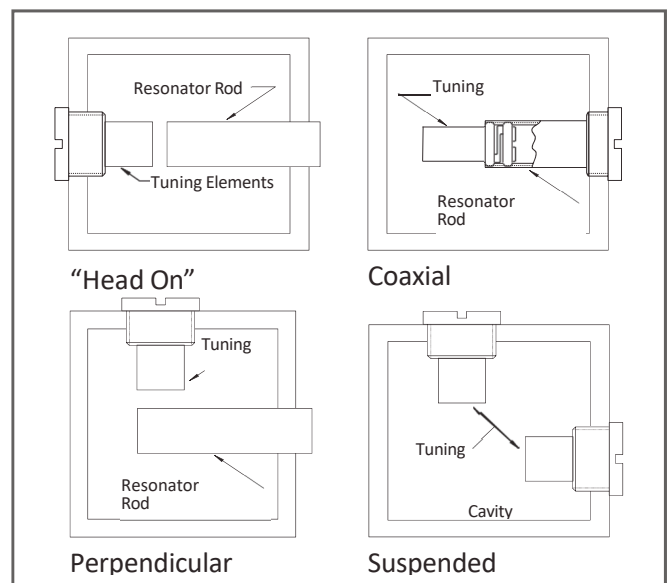

Figure 2. Examples of how the tuning element can be positioned relative to the resonator axis in filters

Filter packaging and access are the primary factors that should ultimately determine the location of the tuning elements.

Upon integrating a pre-tuned filter into a particular circuit, the input and output coupling sections usually require "touch-up" for optimum circuit performance. The self-locking, one-hand tuning capability of Johanson Microwave Tuning Elements is especially helpful for this. Additionally, the broad range of available rotor materials can address even the most perplexing temperature compensation requirements.

Circuit Q aside, the wider the range of capacitive loading, the greater the frequency range. The primary factors that govern maximum capacitive loading include the tuning element's surface finish, material, pitch resolution, and maximum diameter. For optimum results, tuning elements must be positioned at the points of maximum field intensity. In plateline filters, these points are located at the open end of each inductive resonant section. Resonant points of waveguide filters designed to propagate the TE₁₀ mode are located along the center axis of the "a," or broad dimension of the waveguide. Figure 3 shows several sections of a combline filter with microwave tuning elements properly positioned.

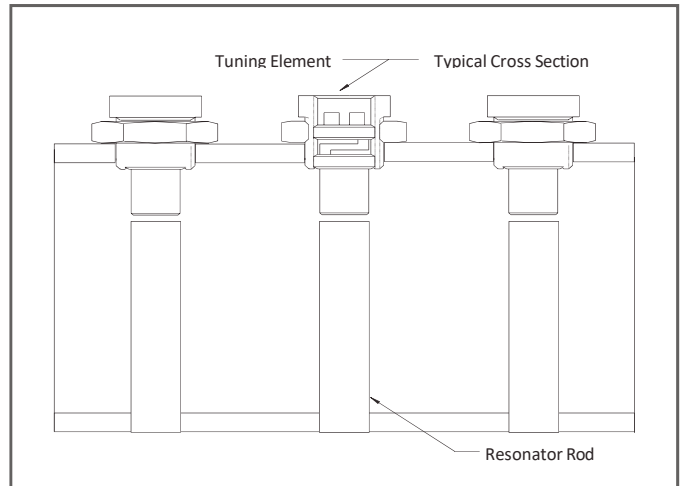

Figure 3. Combline filter section

When rotated inward, the microwave tuning elements increase capacitive loading, lowering the resonant frequency and loaded Q. Although somewhat affected by intersection coupling, bandwidth is increased. This capacitive loading or electrical elongation of the resonant sections explains why broadband filters occupy less space than their narrow counterparts. Figure 4 shows a popular method of achieving maximum capacitance loading by coaxially mounting tuning elements near the inner diameter (ID) of the fixed rod section.

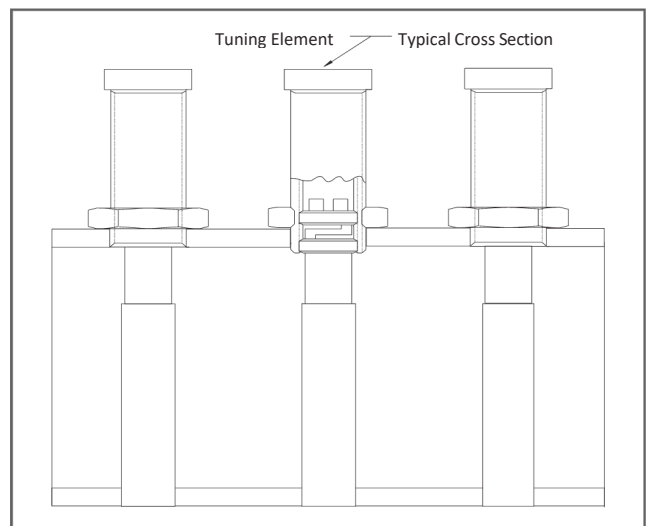

Figure 4. Coaxial Mounting

Should a thin, high-K dielectric sleeve be inserted between the tuning element outer diameter (OD) and rod ID, even more loading can be accomplished.

LC TUNING ELEMENTS

Designed especially for combline, interdigital, and coaxial cavity filters, the Johanson LC Tuning Elements (series 6939, 6940, and 6941) eliminate the need for separate resonator rods and tuning elements. The mounting bushing of LC Tuning Elements is the filter's resonant rod section.

The coaxially mounted tuning rotor fine tunes the resonator to the precise electrical length as shown in Figure 5.

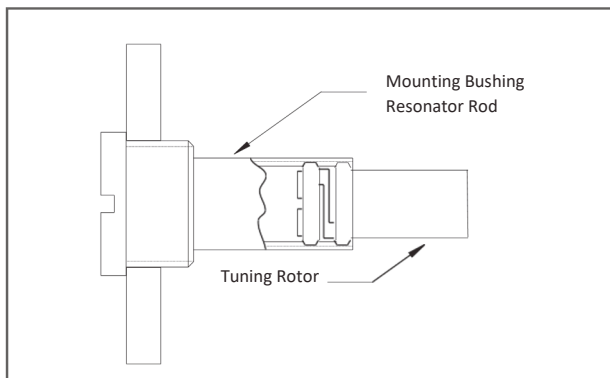

Figure 5. LC Configuration

In high-Q applications where wideband tuning is a requirement, the direct-coupled transverse electric and magnetic (TEM) mode coaxial configuration is usually used. A long-travel tuning post is selected that will cover the desired range. The circuit is then designed around the tunable posts so that each section approximates 76 ohms of optimum resonator Q and the best selectivity. Figure 6 shows this type of configuration with each section lightly iris-coupled.

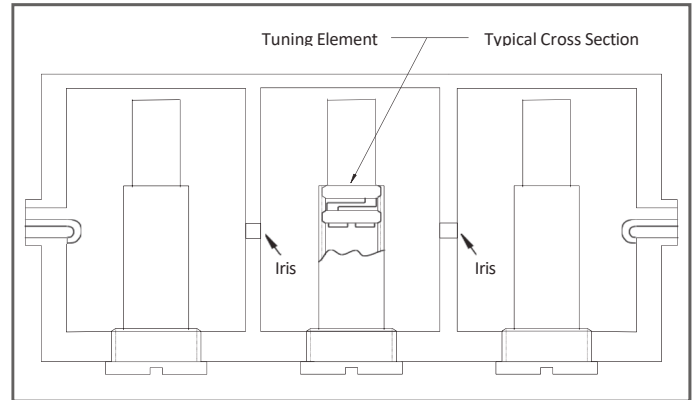

Figure 6. Iris Coupled Coaxial Cavity

It is important to note that whenever tuning elements are mounted in the high-current region of any microwave circuit, intimate contact with the ground will ensure minimum circuit loss. This can be accomplished with tightly secured fine pitch mounting threads and/or soldered joints.

At frequencies above the C band, concerns about circuit losses usually dominate other factors. This includes shallow skin depth, propagation, material and plating conductivity, surface finish, and contact resistance, which can act together to erode theoretical circuit performance. But, since Johanson Microwave Tuning Elements incorporate a self-locking, constant torque mechanism with negligible contact resistance, surface finishes of 32 μin , and a wide range of plating options, you can better meet the stringent requirements of high Q, high frequency, and mechanical tuning for these applications versus using other tuning tools.

OSCILLATORS

Oscillators can be thought of as filters that contain a power generation device such as a transistor, bulk effect device, or diode. Therefore, tuning is accomplished in a similar manner to what is done

with filters. In most instances, the power generation device does not determine the final frequency and an associated cavity or resonant structure provides ultimate control. In the resonant structure, this is where the opportunity exists to not only mechanically tune the oscillator but to temperature compensate it as well. A single Johanson Microwave Tuning Element of the proper configuration and material can be the most cost-effective and efficient method of satisfying both mechanical tuning and temperature compensation.

The Gunn Oscillator application shown in Figure 7 is a typical example of collateral tuning and temperature compensation. The Gunn Oscillator is an ideal application for low-loss tuning elements. While impedance considerations dictate the Gunn Diode location, tuning resolution determines tuner location.

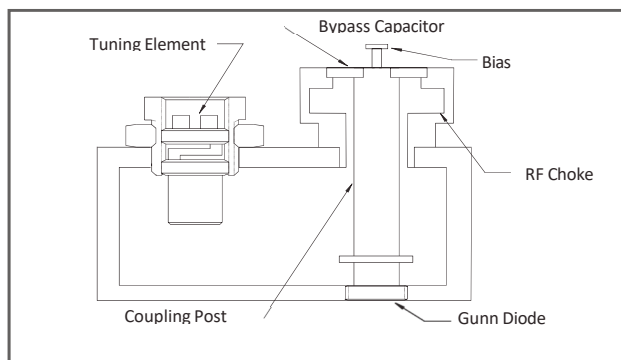

Figure 7. Gunn Oscillator Application

IMPEDANCE TRANSFORMERS

Microwave tuning elements and tuning rotors may be used to introduce shunt susceptance at specific locations along the length of a coaxial or microstrip impedance transformer. The proper selection of metallic or dielectric tuning elements enables the

designer to custom-tune critical circuits without modifying the physical properties of the transmission line. This type of tuning is especially useful and cost effective when matching expensive field-effect transistors (FETs), bipolars, and other active devices in critical circuits where device selection is necessary.

MICROWAVE TUNING ELEMENT CATEGORIES

METALLIC

The metallic tuning elements (series 6924, 6925, 6926, 6927, 6928, 6929, and 6965) consist of a copper alloy mounting bushing with an integral tuning rotor of the same material. Although construction details have been addressed previously, it should be mentioned that the mounting bushing with its associated locking nut is frequently used as a "coarse" frequency adjustment while the rotor finalizes the intended frequency.

At microwave frequencies, the configuration and placement of tuning elements in a circuit play a vital role in circuit performance. Tuning rotor exposure should be kept to a minimum and placement should be where circuit voltage fields are maximum and RF currents minimum. An obvious exception to this method exists when maximum tuning resolution requires the relocation of adjustment to an area of less intense electric field at the expenses of slightly degraded Q. The alternate approach of using a smaller diameter tuner may also be effective.

DIELECTRIC

Dielectric tuning elements are used whenever low-loss/high-resolution tuning is required. When a dielectric wand is introduced into a cavity, the resonant frequency is lowered due to the cavity "appearing" larger in proportion to the square root of k_e of the dielectric material. The exact change is also influenced by other factors such as wand penetration, diameter, and placement.

The following three basic dielectrics are used in Johanson Microwave Tuning Elements:

1. Sapphire
2. Quartz
3. Alumina

A matrix of the electrical properties of each dielectric at 10GHz is shown below:

Dielectric Material	Approximate k_e @ 10GHz	Approximate DF @ 10GHz
Sapphire	9.9	.0001
Quartz	3.8	.0001
Alumina	9.7	.0002

To avoid the phenomenon of wand resonance, which is where the tuning wand itself appears as a secondary cavity in the fundamental operating mode, care must be exercised in the selection of dielectric tuners. Secondary wand resonance is a function of dielectric constant and diameter. The following equation can be used to calculate the approximate cutoff wavelength where this condition could occur:

$$\text{Cutoff Wavelength} = 1.705 (D k_e)^{1/2}$$

D = wand diameter in inches and
 k_e = wand dielectric constant

Dielectric tuning elements may also be used for high tuning resolution in interdigital, combline, and coaxial filters with the additional benefit of reduced losses.

RESISTIVE

The 6950 series tuning elements provide a consistent and accurate means of attenuating microwave energy. When properly located, the magnetically loaded epoxide wand exhibits broadband lossy properties. In addition to simple power reduction, the 6950 series is also used to introduce a precision return loss where critical impedance matching between active and passive components must be achieved.

TUNING ROTORS

In addition to the standard Johanson Microwave Tuning Elements, Microwave Tuning Rotors are available in Johanson series 6930, L6316, and L6990. The use of these lubricated tuning rotors without mounting bushings is sometimes necessary where center-to-center spacing of high-density circuits precludes the use of a mounting bushing. In such cases, appropriate taps and tap drills are available to assure proper thread engagement. Tuning rotors are available in the same materials as their tuning element counterparts.

TUNING DEVICES FOR DIELECTRIC RESONATOR OSCILLATORS AND FILTERS

To generate and filter microwave frequencies in much smaller spaces while still reducing costs, dielectric resonance technology is the answer. In these devices, the basic metallic cavity resonator is replaced by a dielectric resonator several times smaller and more stable with temperature. High Q materials now available with a dielectric constant between 20 and 90 are used for these dielectric resonator oscillator (DRO) applications.

Frequency stability of DROs in many cases is $0\pm 1\text{ppm/C}$. In most cases, the DRO is comprised of a FET oscillator section coupled to a dielectric stabilization section. In other designs, Gunn diodes or bipolar transistors are used as the active devices. In such cases, the basic design criteria for the puck and tuner remain essentially unchanged.

To summarize, a DRO is an inexpensive way to generate microwave frequencies with exceptionally good oscillators. Tuning of dielectric resonant filters is essentially identical to that of DROs.

DIELECTRIC RESONATOR TUNERS

As a matter of practical necessity, DROs must be mechanically tuned to the desired operation frequency. Temperature compensation is accomplished with the proper selection of tuning wand material. Our line of dielectric resonator tuners (DRTs) known as the Johanson DYNA-TRIM™ can meet these needs.

DYNA-TRIM™ DRTs can be used by any organization involved in the generation or filtering of microwaves. This includes military, commercial, and consumer segments with end products ranging from radar and communications systems to electronic countermeasures to door openers to radar detectors and other related devices. The specific circuit most likely to use a DRO is the local oscillator section.

DYNA-TRIM™ is available in three basic configurations to satisfy the unique demands of the military, commercial, and consumer markets. Let's look at each configuration.

MILITARY DYNA-TRIM™

The Military DYNA-TRIM™ consists of metallic bushing with an integral hermetically sealed ceramic dielectric housing where an adjustable tuning rotor is located. A detailed overview of the military DYNA-TRIM™ is shown in Figure 8.

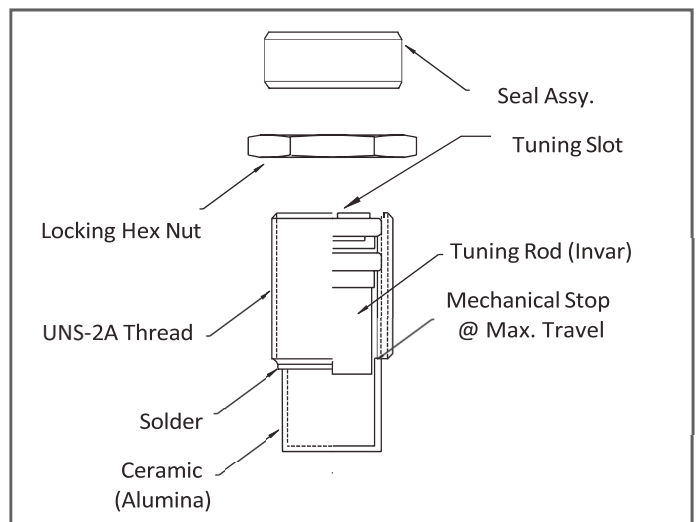

Figure 8. A diagram detailing all the components of the military DYNA-TRIM™ option.

Notice the mechanical captivation of the rotor which prevents contact with the dielectric housing when tuned to the maximum travel position. The appropriate DYNA-TRIM™ option is selected according to a diametric parity with the DRO puck and is installed directly above and in close proximity to the puck by screwing in the mounting bushing and securing it with the locking nut. Since tuning rotor proximity affects bandwidth, the tuner-to-puck gap is critical and must be selected carefully and maintained during a particular production run. To achieve a leak rate in accordance with the MIL-STD-883 standard, the mounting bushing must be soldered in place. Rotor materials selected primarily for temperature compensation purposes include brass and invar.

COMMERCIAL DYNA-TRIM™

The commercial DYNA-TRIM™ as shown in Figure 9, is not hermetic but features a process seal designed to prevent intrusion of dust, cleaning agents, and atmospheric contamination. A variety of materials are available.

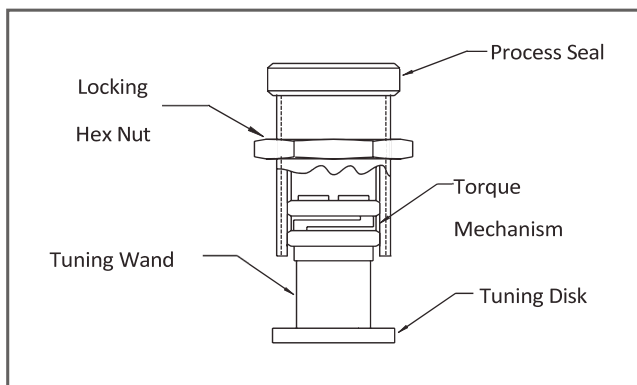

Figure 9. A diagram detailing all the components of the commercial DYNA-TRIM™ option.

As shown, the Johanson torque mechanism eliminates the need for locking nuts or jam screws. Tuning resolutions of 64 threads per inch are standard. Long-term sealing is accomplished with the installation of a seal assembly that consists of a threaded metallic cap with an internal silicon rubber gasket. With a soldered mounting bushing and seal assembly installed, the commercial DYNA-TRIM™ meets the gross leak requirements of MIL-PRF-14409.

CONSUMER DYNA-TRIM™

The consumer DYNA-TRIM™ is designed to address cost-sensitive DRO tuning requirements while providing a precision surface finish on high-resolution threads.

These units consist of a threaded rotor with a hexagonal locking nut. The basic configuration shown in Figure 10 is available in free-machining brass and a variety of thread sizes and optional plating finishes are possible.

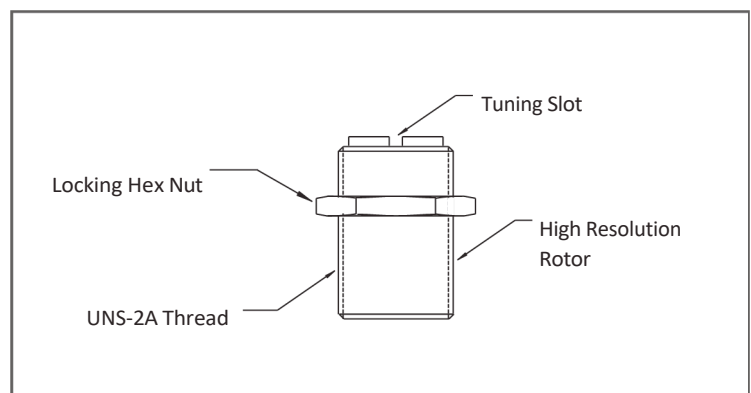

Figure 10. A diagram detailing all the components of the consumer DYNA-TRIM™ option.

OPTIONS FOR ALL YOUR TUNING NEEDS

With our comprehensive line of microwave tuning elements, tuning rotors, and tuning devices for DROs, we are sure to have an option that can satisfy all your tuning needs while also reducing tuning times.

[Contact us today](#) to discuss which tuning element is right for your application's specifications.