



Banding System Shield Termination Tools

BAND-IT® Tools and Tool Kits for Reliable Shield Termination

Fast, Cost-Effective Field and Factory Terminations

The BAND-IT® clamping system provides quick and highly reliable termination of braided metallic shielding or fabric braid. Banding technology was first introduced in our industry in 1985 as a solution to the field repair of magnaformed shield terminations on installed cable assemblies for the B-1 bomber. Banding has been a staple of the industry ever since.



Reliable termination is quickly and easily accomplished in the field with Band-It® precalibrated pocket-sized hand tools. High-speed, mass termination production is afforded by the pneumatic clamping tool.

Reliable RFI/EMI/EMP Terminations

The unique low profile and smooth inside diameter of the one-piece type 304 austenitic stainless steel clamping band virtually eliminates RFI/EMI/EMP leakage paths. The lock maintains constant tension under extreme environmental conditions. BAND-IT® has passed severe shock, vibration and thermal cycle testing with negligible deterioration of shell conductivity.

Single Piece Band Construction

No welding, soldering, magna forming, and no crimping! The clamping bands provide quick, easy and cost-effective shielding terminations. (Note: Bands must be double coiled.)

Clamp Small Diameters Easily, Reliably

Double-wrapped, the clamping band is designed to clamp small diameters as easily, quickly and reliably as large diameters.



Band-It® clamping bands are precision constructed of 300 Series SST/Passivate, and designed for use with Band-It® Hand Banding Tool or the Pneumatic Banding Tool.

The bands are offered in the following four configurations to suit a wide range of requirements: Double-wrapped, the Standard Band will accommodate diameters up to approximately 1.8 inches. The Extended Length Standard Band when double-wrapped will accommodate diameters up to approximately 2.5 inches (63.5mm). The Micro Band will accommodate diameters up to approximately .88 inches (22.5mm) when double-wrapped. The Extended Length Micro Band will accommodate diameters to approximately 1.88 inches (47.8mm) when double-wrapped. All Band-It® clamping bands may be ordered flat or precoiled in bagged and tagged quantities from 1 to 100.

Quick, Easy Field Terminations with the Precalibrated Hand Tool

The precalibrated hand tool is lightweight and pocket-sized, affording fast braided RFI/EMI/EMP shield termination in the field.

Pneumatic Banding Tool for High-Speed Mass Production

The pneumatic clamping tool offers the capability to tackle high volume braided shielding terminations quickly and easily.

Glenair Assembly Tools Help Prevent Distortion and False Tightening Problems

Backshell tightening tools are available which provide virtually a full 360° gripping surface on backshell coupling nuts. These innovative tools minimize the possibility of coupling nut distortion and false tightening problems which can be caused by soft-jaw pliers or strap wrenches.

Reliable Installation of Glenair Backshells on Circular Connectors

When used with the appropriate connector holders and torque wrenches, Glenair Backshell Assembly

Tools provide the user with consistent, repeatable backshell installations. Designed primarily for production assembly use, the tools can also be used equally well for successful field maintenance operations.

Glenair Backshell Assembly Tools may also be utilized effectively with backshell rotatable couplers produced by other manufacturers, providing the "B" reference diameters are consistent with Glenair values.

Recommended Tightening Procedures

Recommended tightening procedures, tools and torque values offered by Glenair are intended as an aid to properly fasten the backshell to the connector interface threads. Glenair offers a variety of tools to accomplish proper tightening; our 600 Series pliers with replaceable pads are configured to make maximum circumferential support to each specific size backshell to be tightened, our TG70 strap wrench (page 6) is intended for general use on any diameter between .50 to 3.00 inches. Hand-held and bench-mount torque wrenches accommodate our 600-005 plug or receptacle connector holders (see *Backshell Assembly Tool* catalog).

When tightening backshell onto connectors, it is important to follow Glenair's recommended procedures for each tool being used.

When tightening backshells with rotatable coupling nuts, Glenair recommends the backshell to be hand tightened to engage the connectors interlocking teeth or spline features, making sure the teeth are fully engaged before fully torquing with our tools. We also suggest retorquing by removing the tool and reinstalling the tool approximately 90° away from the initial position and tightening to the connector manufacturer's recommended value.

Composite backshells should be tightened to the values shown for MIL-C-85049 light and medium duty torque. Secondary components such as: Glenair's cable clamps, gland sealing nuts, sleeves or adapters, not directly fastened to the connector should be tightened 40 to 60 inch pounds to insure proper performance.

Four Easy Steps for Proper Backshell Assembly

1. Select plug or receptacle holder (most holder series provide "universal polarization", but a few connector series require specific polarization for each alternate keying arrangement).
2. Set desired torque on torque wrench.

3. Mount holder on square drive of torque wrench. Carefully mate with connector, and hand-tighten Glenair backshell coupling. To assure proper mating, anti-rotation teeth must be fully engaged.
4. Tighten rotatable coupler with assembly tool. Do not use excessive grip on handles. When coupler begins to tighten, relax grip and rotate assembly tool back 90°, then resume grip and continue to tighten; repeating this sequence until desired torque level is reached.

CAUTION: Do not apply torque in excess of signal setting. Excess torque will cause signal pointer to reset and give erroneous readings.

Setting Torque Levels

To verify proper backshell installation values, electrical signals are built into bench-mounted (audio) and hand-held (light) torque wrenches. The procedure for setting torque levels is the same for both units.

Setting Desired Torque for Right-Hand Thread Tightening

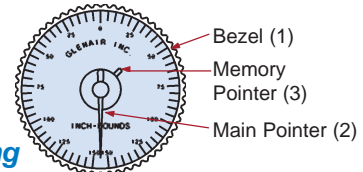

To set torque, turn Bezel (1) clockwise until signal is on. Continue to turn Bezel until Main Pointer (2) is at desired torque level on scale. You may cover the audio signal during this procedure to minimize noise level when setting the bench-mounted unit.

The Memory Pointer (3) is set by the above procedure. With this accomplished, turn Bezel counter-clockwise until the Main Pointer is aligned with zero on the scale. Your torque wrench is now ready for operation.

Setting Desired Torque for Left-Handed Thread Tightening

Simply reverse the above procedure for setting the desired torque for left-hand thread tightening.

Resetting the Memory Pointer

When you wish to change torque levels, rotate the Bezel counter-clockwise until the signal is on. Continue to rotate Bezel until Memory Pointer is aligned with zero on the scale. Now repeat the above procedure for setting torque.

Standard Band 600-052 Precoiled Standard Band 600-052-1

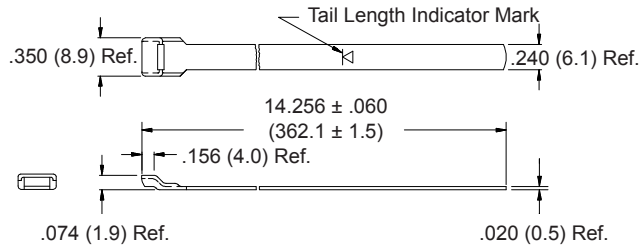

The 600-052 Standard Band is precision constructed of 300 Series SST/Passivate I.A.W AMS 2700 and designed for use with the 600-058 Hand Banding Tool or the 600-067 Pneumatic Banding Tool. Double-wrapped bands will accommodate diameters up to approximately 1.8 inches (45.7). Bands may be ordered flat (600-052) or precoiled (600-052-1). Bands come bagged and tagged in quantities from 1 to 100.

Reference: **BAND-IT®** part number A10086

Extended-Length Standard Band 600-090 Precoiled Extended-Length Standard Band 600-090-1

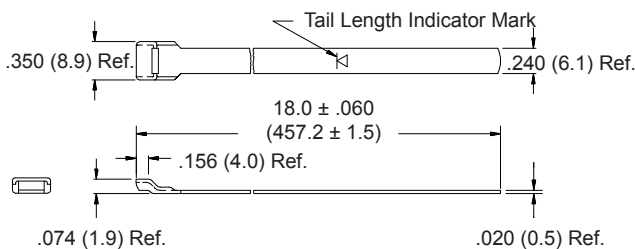

The 600-090 Extended Length Standard Band is precision constructed of 300 Series SST/Passivate I.A.W AMS 2700, and designed for use with the 600-058 Hand Banding Tool or the 600-067 Pneumatic Banding Tool. Double-wrapped bands will accommodate diameters up to approximately 2.5 inches (63.5). Bands may be ordered flat (600-090), or precoiled (600-090-1). Bands come bagged and tagged in quantities from 1 to 100.

Reference: **BAND-IT®** part number A11086

Micro-Band 600-057 Precoiled Micro-Band 600-057-1

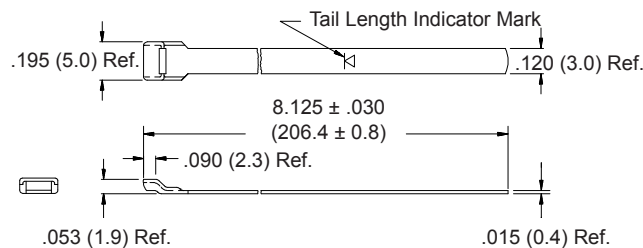

The 600-057 Micro Band is precision constructed of 300 Series SST/Passivate I.A.W AMS 2700, and designed for use with the 600-061 Hand Banding Tool or the 600-068 Pneumatic Banding Tool. Double-wrapped bands will accommodate diameters up to approximately .88 inches (22.4). Bands may be ordered flat (600-057), or precoiled (600-057-1). Bands come bagged and tagged in quantities from 1 to 100.

Reference: **BAND-IT®** part number A31186

Extended Length Micro-Band 600-083 Precoiled Micro-Band 600-083-1

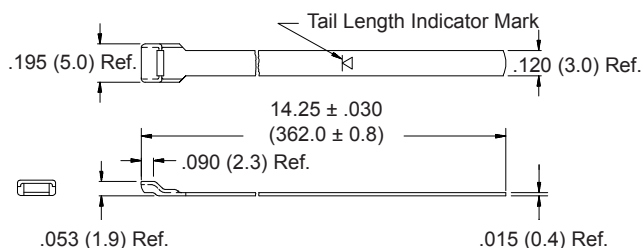

The 600-083 Extended Length Micro-Band is precision constructed of 300 Series SST/Passivate I.A.W AMS 2700, and designed for use with the 600-061 Hand Banding Tool or the 600-068 Pneumatic Banding Tool. Double-wrapped bands will accommodate diameters up to approximately 1.88 inches (47.8). Bands may be ordered flat (600-083), or precoiled (600-083-1). Bands come bagged and tagged in quantities from 1 to 100.

Reference: **BAND-IT®** part number A31086.

Hand Banding Tool 600-058

The **600-058 Hand Banding Tool** weighs 1.18 lbs., and is designed for standard clamping bands 600-052 and 600-090 in a tension range from 100 to 180 lbs. Calibrate at 150 lbs. ± 5 lbs. for most shield terminations. Tool and band should never be lubricated.

Reference: **BAND-IT®** part number A40199.

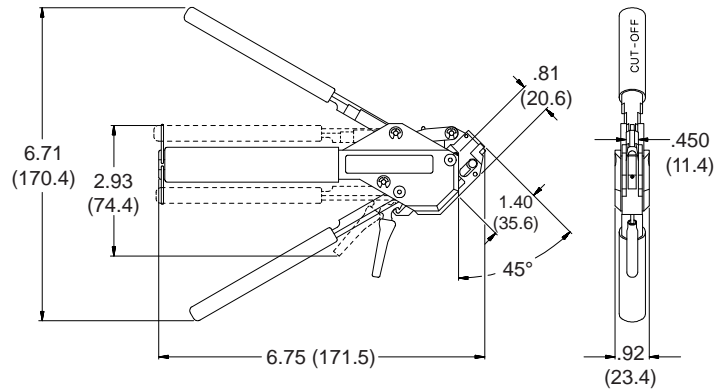

Hand Micro Banding Tool 600-061

The **600-061 Hand Micro Banding Tool** weighs 1.18 lbs., and is designed for micro clamping bands 600-057 and 600-083 in a tension range from 50 to 85 lbs. Calibrate at 75lbs +2 lbs. -7 lbs. for most shield terminations. Tool and band should never be lubricated.

Reference: **BAND-IT®** part number A30199.

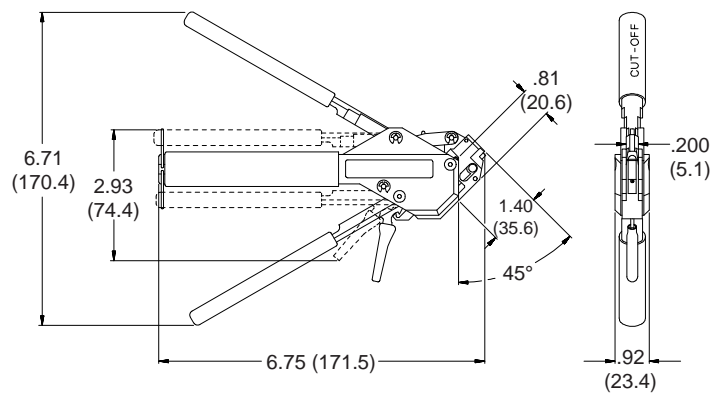

Metric Dimensions (mm) are indicated in parentheses.