



Application Note 2024

High-Voltage Contactors

Inrush current in contactors

How to utilize contactors properly in a capacitive load circuit

One of the main causes of contactor failure is tack welding. The classic approach to avoid this failure is using pre-charge circuits. They protect electrical systems against damaging inrush currents when they are switched on, particularly in applications with capacitive loads. They gradually charge the capacitance

and thus prevent abrupt current peaks that may damage contactors and trigger protection devices. Ensuring controlled current flow until the voltage stabilizes, pre-charge circuits are crucial for system longevity, especially in high-voltage applications such as electric vehicles and charging stations. Here it is vital to reduce both the magnitude and duration of the inrush current.

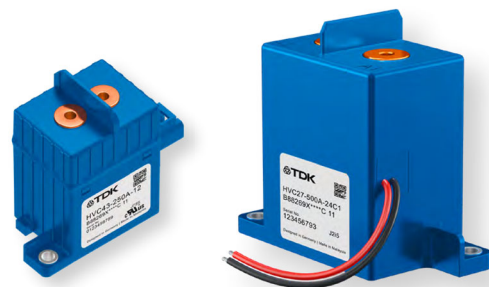
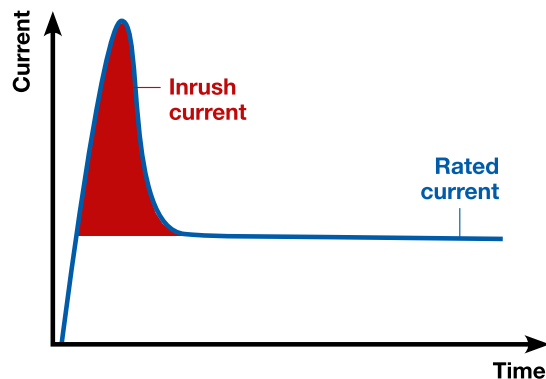

More information

www.tdk-electronics.tdk.com/en/hvc_presentation
or contact your local sales office

High-Voltage Contactors

Inrush current in contactors

1. Causes of inrush current

Inrush current can be caused by resistive, inductive, or capacitive loads, with capacitive loads posing the greatest risk due to their rapid current rise characteristic.

Understanding the underlying causes of inrush current is essential for designing effective pre-charge circuits that are tailored to specific application requirements.

2. Using a pre-charge circuit

The proper sequence of operations is crucial for effectively utilizing pre-charge circuits to power up electrical systems

safely. Monitoring the voltage rise and controlling the pre-charge duration are essential during the process.

Relay timing chart

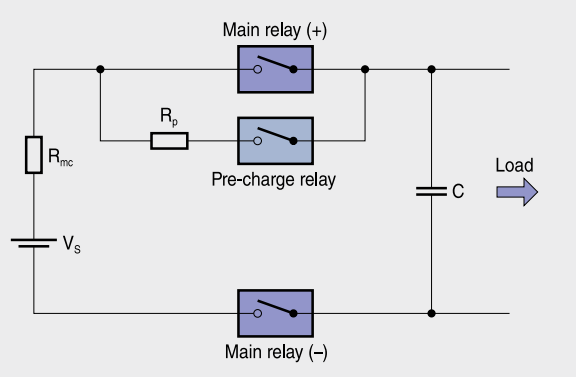
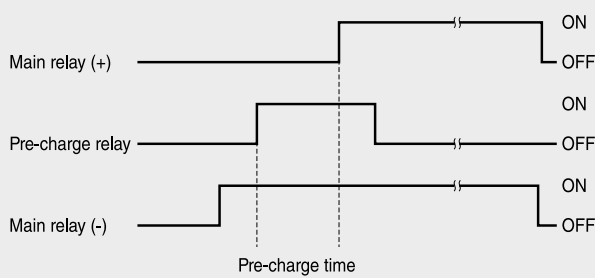

3. Designing a pre-charge circuit

Designing a pre-charge circuit involves selecting appropriate components such as pre-charge contactors and resistors based on the system specifications and the desired pre-charge duration. Calculations for the

resistor values and the power dissipation are crucial for the proper operation of the circuit and the longevity of the components.

4. Calculation of pre-charge circuits

The following parameters must be known:

- Supply voltage of the system (V_s)
- Capacitance that needs to be charged (C)
- Pre-charge resistance (R_p)
- Parasitic resistance of the main circuit (R_{mc})

The time constant τ can be calculated with the following equation:

$$\tau = R_p \cdot C \quad 1$$

The voltage across the capacitor V_C after the time t since the supply voltage is applied is:

$$V_C(t) = V_s \left(1 - e^{-\frac{t}{\tau}}\right) \quad 2$$

The remaining differential voltage across the main contactor can be calculated, as capacitors are considered fully charged after a time of five time constants (5τ). Since the only remaining current limiting resistances during the closing of the main contactor are the parasitic resistances (contact resistances, wire resistance, source resistance, series resistances of other components [e.g. fuse]), the expected inrush current i_{SC} can be calculated using Ohm's law:

$$i_{SC} = \frac{V_C}{R_{mc}} \quad 3$$

Here, V_C is the voltage across the capacitor, and R_{mc} is the parasitic resistance in the main circuit once the contactor is closed.

High-Voltage Contactors

Inrush current in contactors

5. Pre-charge circuit failure and considerations

Pre-charge circuits can fail if loads on the distribution system are not switched off during pre-charge, risking the pre-charge resistor to burn out. Intelligent pre-charge circuits have features such as timers and counters to

prevent overheating, while the choice of coolable resistors can provide robust solutions for continuous operation. The pre-charge resistor must be rated to handle the power dissipation during pre-charging.

Example:

The working voltage of the system V_S is 500 V, the capacitance C to be charged is 1 mF, and the pre-charge resistance R_p was selected to be 100 Ω . The resulting time constant τ is 0.1 s (see equation 1). Applying the 5τ rule, the pre-charge time is set to be 0.5 s. Using equation 2, the remaining differential voltage after 0.5 s across the main contactor is ~ 3.0 V.

Even with a low parasitic resistance R_{mc} of 0.1 Ω in the circuit, the inrush current I_{SC} will be limited to 30 A (see equation 3). If the 5τ rule is not applied, and the pre-charge ends prematurely, the resulting inrush current will be much higher. Taking our example, a pre-charge cycle that has ended after 2τ (0.2 s) will result in an inrush current of 610 A which will most likely damage the contactor (tack welding).

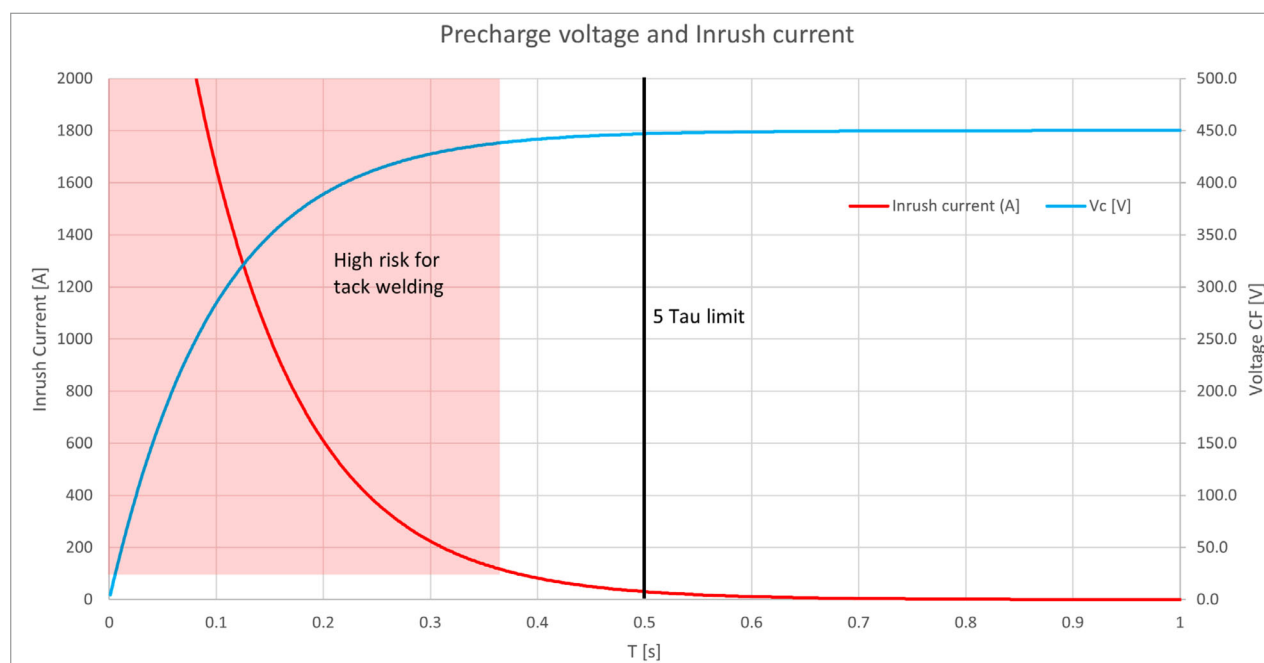

Important information: Some parts of this publication contain statements about the suitability of our products for certain areas of application. These statements are based on our knowledge of typical requirements that are often placed on our products. We expressly point out that these statements cannot be regarded as binding statements about the suitability of our products for a particular customer application. It is incumbent on the customer to check and decide whether a product is suitable for use in a particular application. This publication is only a brief product survey which may be changed from time to time. Our products are described in detail in our data sheets. The Important notes (www.tdk-electronics.tdk.com/ImportantNotes) and the product-specific Cautions and warnings must be observed. All relevant information is available through our sales offices.