



Bourns Inc. Hot Swap Protection

Modern datacenters require continuous uptime and high availability to support cloud services, edge computing, and large-scale data workloads. Server racks, storage arrays, and networking equipment are frequently serviced or expanded while remaining powered and connected.

Hot swap capability enables modules such as drives, power supplies, and network interface cards to be added or removed without shutting down the system, minimizing service disruptions during maintenance or capacity scaling. The hot swap controller acts as the circuit breaker and limits potentially destructive inrush current when a board is plugged in. During hot swap events, power rails and data buses can experience rapid transient events. These transients can exceed component ratings of the server components and the hot swap controller itself, potentially causing hardware damage. Datacenter racks often have densely packed boards with tight voltage and current margins. Protection schemes are necessary to quickly suppress these fast transients without impacting normal operations.

This paper presents solutions from Bourns Inc. to protect hot swap controllers and associated power/data interfaces from adverse transient events in datacenter equipment while maintaining signal integrity and system uptime.

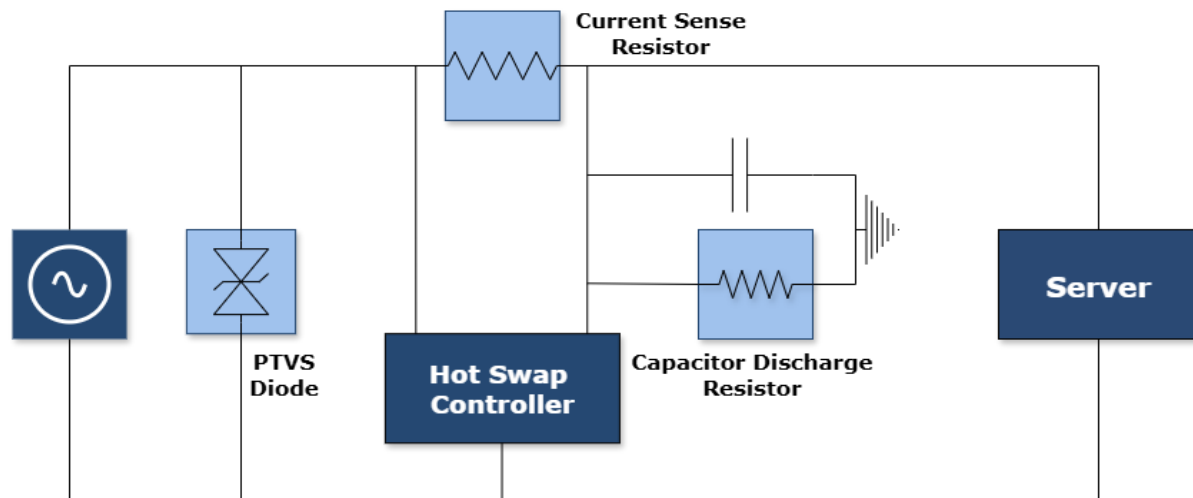

Solution



While the Hot Swap Controller is meant to protect the sensitive server components from inrush currents, the load and controller itself is susceptible to damage from voltage transients, such as inductive kickback from faulty load disconnect. To prevent over voltage damage, a TVS diode can be connected in parallel with the controller to clamp the transient, keeping the voltage below the critical threshold for damage. Modern datacenters are increasing in power requirements.

HOT SWAP PROTECTION

Typical TVS diodes might not be able to handle the voltage and current. The Bourns Power TVS diode family are TVS diodes that are designed for high power capabilities. Specifically, the Bourns [PTVS3-430C-TH](#) is a good choice to clamp the voltage transients. This product supports a working voltage of 430V and has a peak pulse current rating of 3000A for an 8/20 μ s surge. 2 [PTVS3-430C-TH](#) can also be placed in series to provide a working voltage of 860V. Bourns also supports High Power TVS Diodes in a low profile DFN package. The [PTVS1](#) and [PTVS2](#) families support up to 1000A and 2000A respectively (for an 8/20 μ s surge) and up to 86V working voltage. These products are in a compact 8mm x 6mm x 2.5mm DFN package. The PTVS DFN products can also be added in series to reach higher working voltage levels.

When a board is connected to the power source in a datacenter, there is a large inrush current that begins to flow. The hot swap controller limits the inrush current and allows for the controlled charging of a bulk capacitor. The capacitor begins to charge up with the inrush current while the hot swap controller limits the current. A discharge path is needed for this capacitor to prevent residual voltage from remaining after the hot swap event. Bourns recommends the [UB3-8R75G2](#) as a discharge resistor for hot swap designs. The [UB3-8R75G2](#) has an 8 Ω resistance with 2W outpower, making it ideal for discharge applications.

Hot swap controllers sense the inrush current flow through an external current sense resistor to control the charging of the bulk capacitor. Current sense resistors are ideal for hot-swap circuits because of their low resistance value (down to 0.2 milliohm) with the capability to handle high current in the hundreds of amps. For Hot Swap applications, Bourns recommends the [CSS2H-2512R-L500FE](#) Current Sense Resistor which has 0.5 m Ω resistance and supports a 6 W Power Rating @ 70 $^{\circ}$ C with low TCR of \pm 75 PPM/ $^{\circ}$ C.

Product Image	Device Type	Bourns Product Recommendations	Family Specifications and Features	
	PTVS Diode	PTVS3-430C-TH	<ul style="list-style-type: none"> Standoff Voltage: 15-470 V Max. Peak Current: 1-20 kA, 8/20 μs 	<ul style="list-style-type: none"> Offered in through-hole and SMD packages Bidirectional
	DFN PTVS Diode	PTVS1-086C-H	<ul style="list-style-type: none"> Standoff Voltage: 22-86 V Max. Peak Current: 1 kA, 2 kA 8/20 μs 	<ul style="list-style-type: none"> Offered in compact DFN package Bidirectional

HOT SWAP PROTECTION



[Capacitor
Discharge
Wirewound
Resistors](#)

[UB3-8R75G2](#)

- Resistance Range: 0.02-260 kΩ
 - Power Rating: 1 – 15 W
 - Tolerance: 0.01 % - 10 %
- Low TCR: ±20PPM/°C
 - Through-hole package
 - Wirewound technology

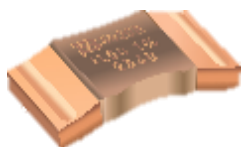

[Current
Sense
Resistors](#)

[CSS2H-2512R-
L500FE](#)

- Resistance Range: 0.2-5 mΩ
 - Power Rating: 1.5-15 W
 - Tolerance: 1 %, 2 %, 5 %
- Temperature Coefficient: 50 ppm
 - Surface mount
 - Low thermal EMF