

HYBRID AND ELECTRIC VEHICLE CONNECTION SYSTEM **SELECTOR GUIDE**



A world of **transportation**

Aptiv has been a trusted automotive supplier for decades, introducing practical innovations in the areas of safety, efficiency, and connectivity. The transportation market has been advancing in these same areas and Aptiv can offer product solutions upgraded to its tougher operational and environmental requirements.

Commercial and recreation vehicles, such as trucks, buses, construction, agriculture equipment and motorcycles, are often exposed to higher levels of environmental forces, including vibration, dust, water, debris, and temperatures. To protect the integrity of the electrical system, high performance connection systems are often required.

To deliver superior performance, a number of complex factors in the electrical system must be addressed in the component design, including sealing, locking features, and materials.

About **Aptiv**

Aptiv is a global technology company that develops safer, greener and more connected solutions, which enable the future of mobility. Headquartered in Gillingham, England, Aptiv has 147,000 employees and operates 14 technical centers, as well as manufacturing sites and customer support centers, in 45 countries.



Image Source : PSA

Visit [aptiv.com](https://www.aptiv.com)

Did you Know?

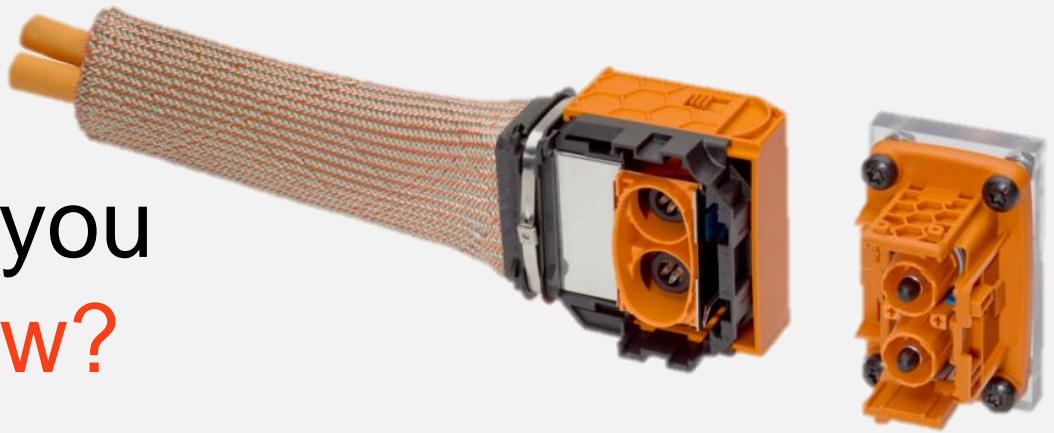

Hybrid and electric vehicles are creating a host of challenges, including the demand for a new generation of high performance, high power connectors and charging solutions. Many additional power electronics devices are added to the vehicle architecture including lithium-ion (Li-ion) batteries, inverters and DC (Direct Current) converters. Their impact on connector design results in handling operation voltages that range from 400V up to 1000 V and carrying currents as high as 250A.

Aptiv is ready when and where you need us

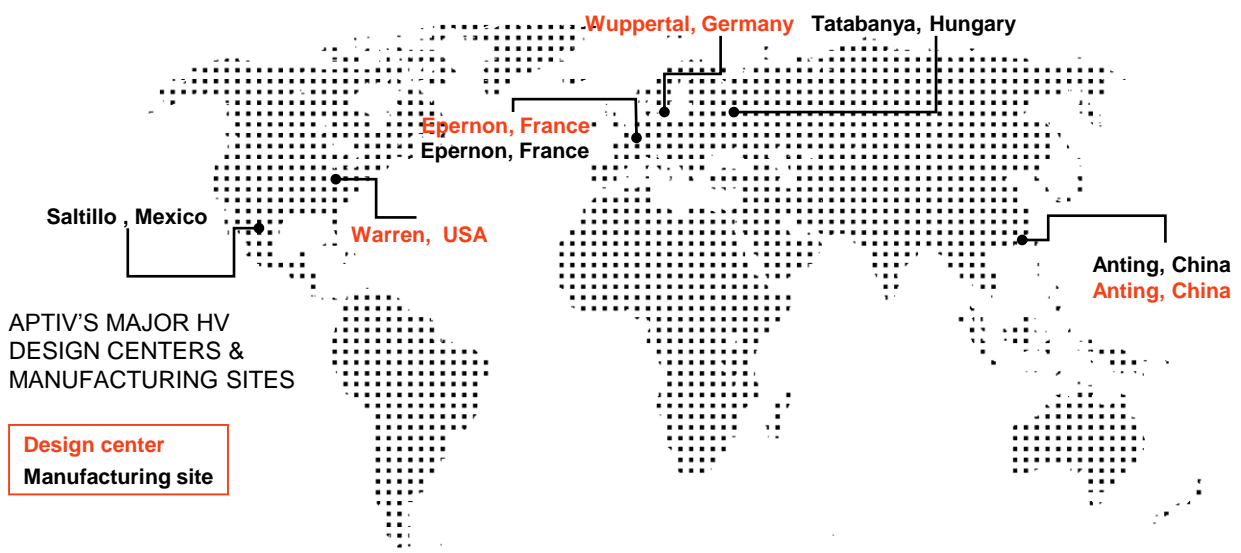

Why is **vehicle electrification** now a reality?

**ENVIRONMENTAL
CONCERNS**



**GOVERNMENT
REGULATIONS AND
INCENTIVES**



**RISING
FUEL COSTS**



Driven by rising fuel costs, environmental concerns and a combination of government regulations and incentives, the market for EVs (Electric Vehicles) and HEVs (Hybrid Electric Vehicles) is now becoming a reality. Vehicle specifications and infrastructure deployment have reached a certain level of industrialization. Standards have already been established for vehicle charging interfaces used on plug-in HEVs and EVs.

There are three standards used throughout the world including SAE J1772 in North America and Japan, IEC62196 Type II in Europe and GB/T 20234 in China. In addition, SAE has established a common footprint for DC (Direct Current) fast charging in North America and Europe. Aptiv offers a complete line of all global charging standards.

Aptiv is currently driving the innovations required for future multi-voltage architectures. Our research and development teams have leveraged the lessons learned from the collaboration with OEM's to focus on technological excellence and to provide real-life electrification performance.

With a unique expertise in architecture optimization and systems integration, the company has created one of the most comprehensive portfolios of the high power connection systems.

Superior **Sealing** Performances



All of our connection systems feature external IP67 sealing performance. To ensure optimum sealing performance, our connectors are designed for the harshest conditions due to a back sealing feature.

Superior **Shielding** Performance



EV and HEV electrical and electronic systems generate unwanted electromagnetic interference (EMI) which radiate from the interconnecting cables. The connection systems are designed by minimizing the paths along which these signals can escape. Our connectors and cabling designs provide high levels of shielding effectiveness to ensure EMI free performance of the complete system.

Superior **Safety** Performances



Our connectors provide finger-proof, touch safe and 2-step disconnection technologies to guarantee optimum safety during all handling operations. They continue to meet with changing requirement of the OEM's in regard to HVIL on a vehicle system and connection system level. Additionally, the company's ErgoMate™ axial mating system helps achieve a lower profile solution while reducing mating forces. Once connected, a CPA (Connector Position Assurance) device must be activated to ensure a 100% safe mating.

A comprehensive product portfolio



High Voltage **Auxiliary** Modules

High Voltage connection systems designed specifically for the voltage and current needs of auxiliary modules, such as A/C compressor, heater, coolant control module, on board-board charger, DC converter, and battery accessory output.

Page 9



High Voltage **Power** Conversion

High Voltage connection systems designed specifically for the voltage and current needs up to 250A. Power conversion modules consist of inverters, drive motors/generators, and High Current/High Voltage battery outputs.

Page 23



High Power 12, 24, **48 Volt** Solutions

Growing requirements and a quickly increasing market for 48 Volt applications drive our technology for innovative solutions. Two key characteristics define these solutions: High current carrying capabilities and high sealing protection.

Page 35



Charging **Solutions**

Unique technologies to help facilitate a global charging infrastructure, from Aptiv's Portable Electric Vehicle Charger and Charge Coupler pigtails for integration into Electric Vehicle Supply Equipment (EVSE). With Aptiv products, hybrid and electric vehicles can be powered safely and efficiently at home or away.

Page 43

Product Applications





E-Heater, DC Converter, Charger, Air Conditioning, Coolant Heater Control

HV battery, E-motor, Inverter, junction box, power electric box

48V Inverter, 48V Battery, Power Distribution boxes, E-charger (e-booster), 12 V battery, DC/DC converter, 12V Electrical Distribution Center





On-vehicle charging inlets
Grid-to-vehicle charging
Charging infrastructure-to-vehicle

Performance key & Aptiv design indicators key

Performance	Voltage 		Amperage 	
	Range 12V – 1000V		Range 10A – 250A	
	Temperature 		Sealing 	
	Class	Ambient Temperature Range	Class	Common Name
	T1	-40°C to +85°C	S1	Unsealed
	T2	-40°C to +100°C	S2	Sealed
	T3	-40°C to +125°C	S3	Sealed
	T4	-40°C to +150°C		(w/high pressure spray)
	Vibration 			
	Class	Common Name	Typical Application	
V1	Chassis Profile	Components on sprung portions of vehicle not coupled to Engine		
V2	Engine Profile	Components coupled to Engine with severe vibration possible		
V3	Severe On-Engine	Components subject to severe vibration		
V4	Extreme Vibration	Used as needed to correlate to extreme vibration areas		

Selector Guide

Auxiliary Modules Solutions

Image	Page #	Application	Description	Temperature Vibration Class	Shielding	Amperage	Voltage	# Ways orientation	Sections
	10-13	On-board charger applications (Level 1 and 2)	On-board charger female	T3 V1	Not shielded	32A at 85°C	600V	2 to 4 power lines / 180°	2 to 5 mm ²
			On-board charger male inline						
			On-board charger header						
	14-15	Battery pack (Aux) DC/DC converter On-board charger PTC Electric Heater Electric air conditioning Electric power Steering	AK class 1 3way female (no HVIL)	Temperature: Level 4/ Vibration Level 2 (LV 215) T4 V1	Shielded multicore cable	32A at 85°C	1000V	2 to 3 power lines / 180°	2.5 to 4 mm ²
			AK class 1 2way female (HVIL pass-through)						
			AK class 1 2way female (HVIL shunt)						
	16-17		APEX280 2way female	T3 V1	Shielded with metal braid				
			APEX280 2way header						
	18-19	Electric air conditioning PTC Electric Heater Charger	Inner connector	T3 V1	Shielded individual cables	35A at 70°C	1000V	2 power lines / 180°	2.5 to 5 mm ²
			HV280 with inner connector header						
			HV280 female						
	20-21	On-board charger	APEX 950 On-Board Charger Connector (HVIL shunt)	T3 V1	Not shielded	125A at 70°C	750V	4 power lines / 180°	10 to 16 mm ²

On-Board Charger Connector Level 1 / Level 2

6 way Device Connection System

APPLICATION

- High voltage unshielded system for on-board charger applications: Level 1(16A) and 2 (32A)

DESCRIPTION

- Sealed connection system
- Capability for four power circuits and two signal circuits
- Unshielded with terminal spacing for HV applications
- Two-stage locking system for electrical protection
- One-stage locking system also available
- Cable range: 2 mm² to 5 mm²
- Capable of multiple keys/indexes
- Electrical protection: Finger-proof IP2XB

Performance

32A@85C

600V DC

Temperature

T3

Vibration

V1

Sealing

S3

Dimensions

Shown in millimeters

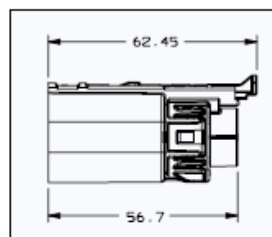
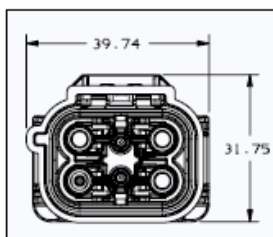
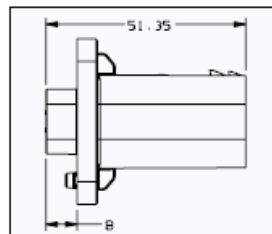
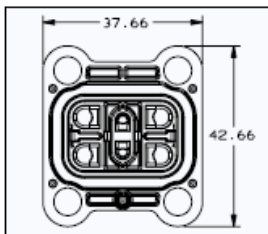



Header connector Part number

Part Number	Key/index	Description	BOM
33229376	101	On-board charger connector - (tool required for disconnection)	1
33229378	101	On-board charger connector - (no tool required)	

Male Terminals

Part Number	Description	BOM
13663724	Male Terminal 1.0 HES Gold required 0.75-1.0mm ²	2
13783283	Male Terminal 2.4 HES Gold required 2-3mm ²	2, 3 or 4
13783284	Male Terminal 2.4 HES Gold required 4-5mm ²	

Mating Part number



Part Number	Key/index	Description	BOM
13879051	101	Level 1 harness connector (2+2) 2-2.5 mm ²	1
13879050	101	Level 1 harness connector (3+2) 2 -2.5 mm ²	
13879049	101	Level 1 harness connector (4+2) 2-2.5 mm ²	
13879048	101	Level 2 harness connector (2+2) 4-5 mm ²	
13879047	101	Level 2 harness connector (3+2) 4-5 mm ²	
13879046	101	Level 2 harness connector (4+2) 4-5 mm ²	

Female Terminals

Part Number	Description	BOM
13663728	Female Terminal 1.0 HES Gold required 0.75-1.0mm ²	2
13783300	Female Terminal 2.4 HES Gold required 2-3mm ²	2, 3 or 4
13783301	Female Terminal 2.4 HES Gold required 4-5mm ²	

On-Board Charger Connector Level 1 / Level 2

6 way Inline Connection System

APPLICATION

- High voltage unshielded system for on-board charger applications (Level 1 and 2)

DESCRIPTION

- Sealed connection system
- Capability for four power circuits and two signal circuits
- Unshielded with terminal spacing for HV applications
- Two-stage locking system for electrical protection
- One-stage locking system also available
- Cable range: 2 mm² to 5 mm²
- Capable of multiple keys/indexes
- Electrical protection: Finger-proof IP2XB

Performance

32A@85C

600V DC

Temperature

T3

Vibration

V1

Sealing

S3

Dimensions

Shown in millimeters

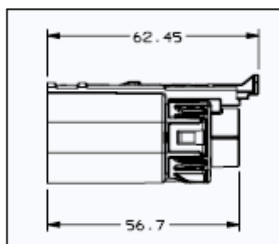
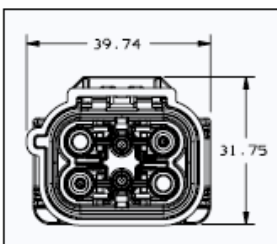
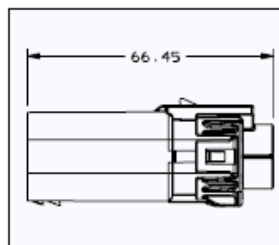
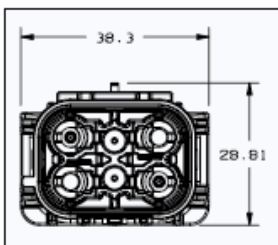



Header connector Part number

Part Number	Key/index	Description	BOM
13990593	101	Level 1 harness connector (2+2)	1
13990592	101	Level 1 harness connector (3+2)	
13990591	101	Level 1 harness connector (4+2)	
13990590	101	Level 2 harness connector (2+2)	
13990589	101	Level 2 harness connector (3+2)	
13990588	101	Level 2 harness connector (4+2)	

Male Terminals

Part Number	Description	BOM
13663724	Male Terminal 1.0 HES Gold required .75-1.0mm ²	2
13783283	Male Terminal 2.4 HES Gold required 2-3mm ²	2, 3 or 4
13783284	Male Terminal 2.4 HES Gold required 4-5mm ²	

Mating Part number



Part Number	Key/index	Description	BOM
13879051	101	Level 1 harness connector (2+2) 2-2.5 mm ²	1
13879050	101	Level 1 harness connector (3+2) 2-2.5 mm ²	
13879049	101	Level 1 harness connector (4+2) 2-2.5 mm ²	
13879048	101	Level 2 harness connector (2+2) 4-5 mm ²	
13879047	101	Level 2 harness connector (3+2) 4-5 mm ²	
13879046	101	Level 2 harness connector (4+2) 4-5 mm ²	

Female Terminals

Part Number	Description	BOM
13663728	Female Terminal 1.0 HES Gold required .75-1.0mm ²	2
13783300	Female Terminal 2.4 HES Gold required 2-3mm ²	2, 3 or 4
13783301	Female Terminal 2.4 HES Gold required 4-5mm ²	

Shield-Pack™ HV280

AK CLASS 1 female connector

APPLICATION

- High voltage accessories connection system

DESCRIPTION

- Sealed connection system
- Two or three HV power circuits (2.8 mm terminal)
- 2 Way: HVIL shunted in harness connection and pass-through HVIL options available
- 3 Way: No HVIL
- Cable range: 2.5 & 4mm² multi-core circuit; 0.5 mm² HVIL circuit (2 way only)
- Four Key/indexes
- Electrical protection: Finger-proof IP2XB

Performance

32A@85C

1000V DC

Temperature T4

Vibration V1

Sealing S3

Dimensions

Shown in millimeters

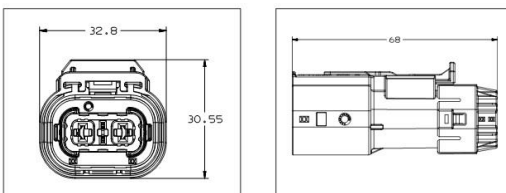

Female connector



Part Number	Description	BOM
33372017	Receptacle Housing Subassembly, 2Way, Code A	1
33372014	Receptacle Housing Subassembly, 2Way, Code B	
33372016	Receptacle Housing Subassembly, 2Way, Code C	
33372015	Receptacle Housing Subassembly, 2Way, Code D	
35061103	Receptacle Housing Subassembly, 2Way, Code E	

Terminals

Part Number	Description	BOM
33522728	DCK 2.8 female terminal 4 mm ²	2
33514302	DCK 2.8 female terminal 2.5 mm ²	
33504709	Duo twin 0,64 male terminal 0,5 mm ² (HVIL pass-through version only)	2

Components

Part Number	Description	BOM		
		2 way, HVIL pass-through	2 way, HVIL Shunt	3 way
35174268	Spacer	1	1	1
35174446	Shielding	2	2	2
35174249	ASM Strain Relief for 3 x 2.5 mm ²			1
35174250	Cable Seal for 3 x 2.5 mm ²			1
35174511	Inner Housing, 2Way	1		
35174507	ASM Strain Relief for 2 x 4.0 mm ²		1	
35174508	Cable Seal for 2 x 4.0 mm ²	1	1	
35174280	Inner ferrule	1	1	1
35174278	Outer ferrule	1	1	1
35174509	Inner Housing Sub-assembly		1	
35174448	Inner Housing, 3Way			1
35174513	TPA (Terminal Position Assurance)	1		
35174510	ASM Strain Relief for 2 x 4.0 + 2 x 0.5 mm ²	1		

APEX® HV280

2 way Connection System with HVIL

APPLICATION

- High voltage peripheral equipment connection system: Air conditioning, PTC, Charger

DESCRIPTION

- Bundle shielding with external braid
- Dual sealing connection system: mated & unmated header
- Panel mount to device with face seal
- Unique integrated electric interlock
- HVIL shunted in harness connector
- Two-stage disconnect for safe unmating
- ErgoMate™ Axial Mating Assist System on harness connector
- Two HV power circuits (2.8 mm terminal)
- Cable range: 2.5 to 4 mm² power circuit; 0.5 to 0.75 mm²
- HVIL circuit
- Two keys/indexes
- Electrical protection: Finger-proof IP2XB

Performance

35A@70C

1000V DC

Temperature

T3

Vibration

V1

Sealing

S3

Dimensions

Shown in millimeters

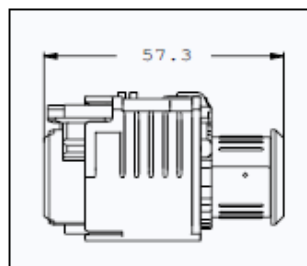
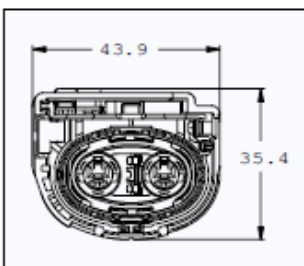
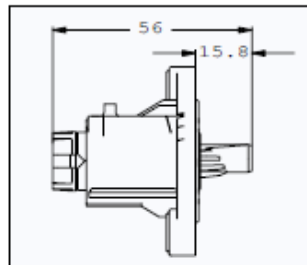
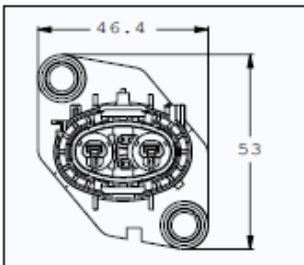



Header connector Part number

Part Number	MPN	Key/index	Description	BOM
33511766	F873110	1	APEX-280 2way header code 1 black	1
33511767	F973110	2	APEX-280 2way header code 2 brown	

Male Terminals

Part Number	MPN	Description	BOM
15516298	NA	APEX 280 male terminal 4 mm ²	2
15509074	NA	APEX 280 male terminal 2.5 mm ²	
10779703	60100734	HVIL- interlock DCS2 1.5 gold-plated male terminal 0,5-1,0 mm ²	2
33511802	60100714	HVIL- interlock DCS2 1.5 gold-plated male terminal 0,22-0,35 mm ²	

Seal

Part Number	MPN	Description	BOM
33512175	NA	APEX 2.8 male & female SWS Red 4 mm ²	2
33512180	NA	APEX 2.8 male & female SWS 2.5 mm ²	
15441379	60993913	DCS 1.5 male red SWS 0,22 - 0,5 mm ²	2
15441380	60993928	DCS 1.5 male grey SWS 0,75 - 1,0 mm ²	

Mating Part number



Part Number	MPN	Key/index	Description	BOM
33517428	F083110	1	APEX-280 2way plug code 1 black	1
33511765	F183110	2	APEX-280 2way plug code 2 brown	

Female Terminals

Part Number	Description	BOM
10810733	APEX 2.8 female terminal 4 mm ²	2
13627267	APEX 2.8 female terminal 2.5 mm ²	

Seal

Part Number	Description	BOM
33512175	APEX 2.8 male & female SWS Red 4 mm ²	2
33512180	APEX 2.8 male & female SWS 2.5 mm ²	

Shield-Pack™ HV280

2 Piece Header with Pluggable Inner Connector

APPLICATION

- Ideal for auxiliary devices/high voltage connection system

DESCRIPTION

- Inner Connector with TPA can be plugged into header during device assembly
- Sealed connection system
- Panel mount to device with face seal
- Internal HVIL (shunt in harness connector)
- Two options available : Two-stage locking system for HVIL time delay - Tool-less mating system
- Two HV power circuits (2.8 mm terminal)
- Finger proof/touch safe
- Cable range: 2 mm² to 5 mm² power circuit; 0.5 mm² HVIL circuit
- Electrical protection: Finger-proof IP2XB

Performance

40A@85C

1000V DC

Temperature T3

Vibration V1

Sealing S3

Dimensions

Shown in millimeters

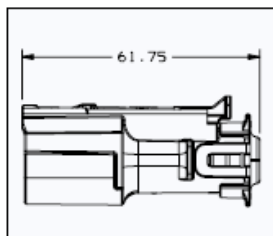
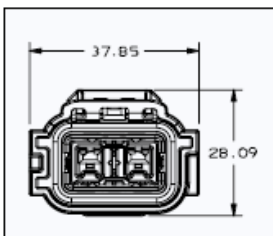
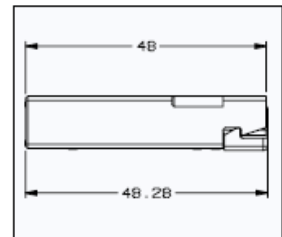
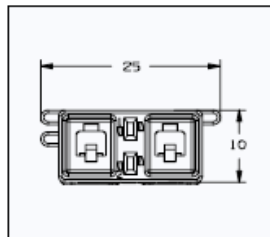
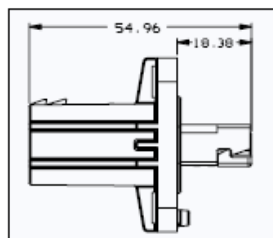
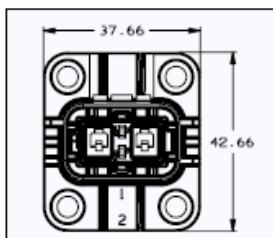

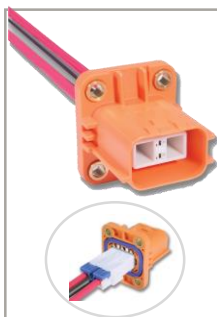

Header & Inner connector Part number

Part Number	Key/index	Description	BOM
33211753	101	Shield-Pack HV280 2 piece header with Loose Inner connector	1
33215445	102	Shield-Pack HV280 2 piece header with Loose Inner connector	
15526394	101	Inner connector	1
15526395	102	Inner connector	

Male Terminals

Part Number	Description	BOM
13753470	2.8 Male terminal - 2.48-3.97 cable OD 1-2 mm ²	2
13753471	2.8 Male terminal - 3-4.09 cable OD / 3 mm ² -5mm ² solder required	
13790534	2.8 Male terminal - 3.40-5.24 cable OD / 4-5 mm ²	
15432235	HVIL terminal	2

TPA

Part Number	Description	BOM
15526390	TPA (Terminal Position Assurance)	1

Mating Part number



Part Number	Key/index	Description	BOM
13824784	101	Shield-Pack HV280 Internal HVIL Shunted - (tool required for disconnection)	1
13830159	102	Shield-Pack HV280 Internal HVIL Shunted - (tool required for disconnection)	
33280354	101	Shield-Pack HV280 Internal HVIL Shunted - (no tool required)	1
33280355	102	Shield-Pack HV280 Internal HVIL Shunted - (no tool required)	

Ferrule

Part Number	Description	BOM
13737698	Inner ferrule 2.57-2.87 cable OD / 14 gage (2mm ²)	2
13737699	Inner ferrule 3.30-3.46 cable OD / 12 gage (3mm ²)	
13737700	Inner ferrule 3.84-4.09 cable OD / 10 ga (5mm ²)	
13737702	Outer Ferrule	2

Female Terminals

Part Number	Description	BOM
13882331	2.8 Female terminal – 3-4-5mm ²	2
13799603	2.8 Female terminal - 1.5-2.5mm ²	

Seal

Part Number	Description	BOM
15513451	Cable seal LSR 10ga	2
15513452	Cable seal LSR 12ga	
15513453	Cable seal LSR 14ga	
15513454	Cable seal LSR 4mm ² EU	

TPA

Part Number	Description	BOM
13824780	TPA/seal retainer Cable 14 ga	1
13824779	TPA/seal retainer Cable 12 ga	
13824778	TPA/seal retainer Cable 10 ga	

APEX® 950 On-Board Charger Connector

4 + 1 Way Connection System with HVIL

APPLICATION

- High voltage unshielded system, especially on-board charger applications

DESCRIPTION

- Sealed in mated or unmated position
- Unshielded 4 + 1 way connector
- Panel mount to device with face seal to module
- Unique integrated electric interlock
- HVIL shunted in harness connector
- ErgoMate™ slider for easy handling and reduced mating force
- 5 HV power circuits (four 9.5 mm and one 2.8 mm terminals)
- Cable range: 10 to 16 mm² power circuit; 0.5 to 0.75 mm² electric interlock
- 1 key/index
- Electrical protection: Finger-proof IP2XB

Performance

125A@70C

750V DC

Temperature

T3

Vibration

V3

Sealing

S3

Dimensions

Shown in millimeters

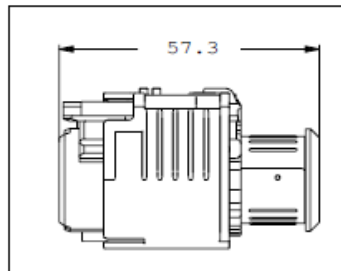
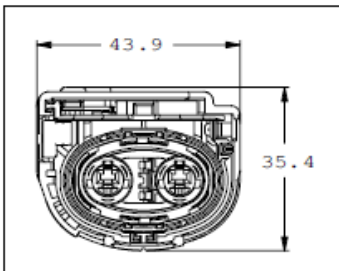
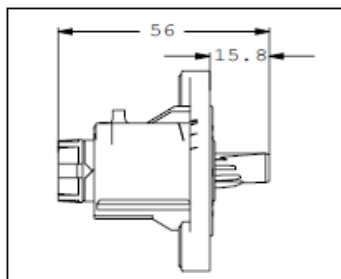
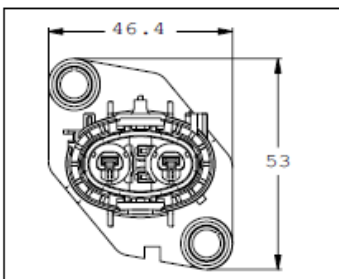

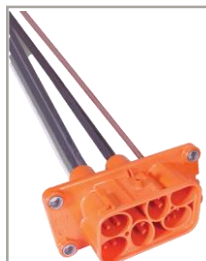

Header connector Part number

Part Number	Key/index	Description	BOM
33402137	1	APEX 950 Header connector Code 1	1

Male Terminals

Part Number	MPN	Description	BOM
33514386	F008900	APEX 950 Male Terminal 10 to 16mm ²	4
15516298		APEX 280 Male Terminal 4 mm ²	1
10779703	60100734	HVIL - Interlock DCS 1.5 Male Terminal AU Sealed 0.5 to 1 mm ²	2

Seal

Part Number	MPN	Description	BOM
33503295	F128900	APEX 950 SWS wire size 16 mm ²	4
33503294	F028900	APEX 950 SWS wire size 10 mm ²	
33512175		APEX 2.8 SWS	1
15441379	60993913	DCS 1.5 SWS red 0.22 to 0.5 mm ²	2

Mating part number



Part Number	Key/index	Description	BOM
33402139	1	APEX 950 connector black Code 1	1

Female Terminals

Part Number	MPN	Description	BOM
33514387	F018900	APEX 950 Female Terminal 10 to 16mm ²	4
10810733	NA	APEX 2.8 Female Terminal 4 mm ²	1









Seal

Part Number	MPN	Description	BOM
33503295	F128900	APEX 950 SWS wire size 16 mm ²	4
33503294	F028900	APEX 950 SWS wire size 10 mm ²	
33512175	NA	APEX 2.8 SWS	1
15441379	60993913	DCS 1.5 SWS red 0.22 to 0.5 mm ²	2



Selector Guide

Power Conversion Solutions

Image	Page #	Application	Description	Temperature Vibration Class	Shielding	Amperage	Voltage	# Ways orientation	Sections																																				
	24-25	Inverter DC/DC Converter Battery junction box power electric box High Voltage Power Distribution	AK class 4 header	Temperature: Level 4 Vibration: Level 3 (LV 215) T4 V2	Shielded individual cables	180A at 140°C (50 mm ²)	1000V	2 ways / 90°	25 to 50 mm ²																																				
			AK class 4 female plug								26-27	RCS800 2way header	T3 V2	Shielded with metal braid	210A at 85°C (50 mm ²)	1000V	2 ways / 90°	35 to 50 mm ²	RCS-800 2way plug	RCS800 female terminal		28-29	RCS890 2way header	T3 V1	Shielded with metal braid	210A at 85°C (50 mm ²)	1000V	2 ways / 180°	35 to 50 mm ²	RCS-890 2way plug	RCS890 female terminal		30-31	Plastic AK pass-through 1way	Temperature: Level 4 Vibration: Level 3 (LV 215) T4 V3	Shielded individual cables	200A at 140°C (50 mm ²)	1000V	1 to 3 ways / 180°	16 to 50 mm ²	Plastic AK pass-through 2way	Plastic AK pass-through 3way		32-33	Metal pass through 25 mm ²
	26-27		RCS800 2way header	T3 V2	Shielded with metal braid	210A at 85°C (50 mm ²)	1000V	2 ways / 90°	35 to 50 mm ²																																				
			RCS-800 2way plug																																										
			RCS800 female terminal																																										
	28-29		RCS890 2way header	T3 V1	Shielded with metal braid	210A at 85°C (50 mm ²)	1000V	2 ways / 180°	35 to 50 mm ²																																				
			RCS-890 2way plug																																										
			RCS890 female terminal																																										
	30-31		Plastic AK pass-through 1way	Temperature: Level 4 Vibration: Level 3 (LV 215) T4 V3	Shielded individual cables	200A at 140°C (50 mm ²)	1000V	1 to 3 ways / 180°	16 to 50 mm ²																																				
			Plastic AK pass-through 2way																																										
		Plastic AK pass-through 3way																																											
	32-33	Metal pass through 25 mm ²	T3 V4	Shielded individual cables	250A at 85°C (50 mm ²)	1000V	1 way with indexes / 180°	25 to 50 mm ²																																					
		Metal pass through 35 mm ²																																											
		Metal pass through 50 mm ²																																											

HV890 AK Class 4

2 Way Connection System with HVIL

APPLICATION

- High voltage/high current modules: inverter, battery, junction box, power electric box

DESCRIPTION

- Number of ways: 2
- Number of indexes: 4
- Terminal Size/Style: Ø8mm Pin & Sleeve
- Wire range: 25mm² to 50mm²
- Fully interchangeable with other AK products
- Vibration severity 3 LV215
- Temperature severity 4 LV215
- Electrical Protection: Finger-proof IP2XB

Performance

170A@140C

1000V DC

Temperature T4

Vibration V2

Sealing S3

Dimensions

Shown in millimeters

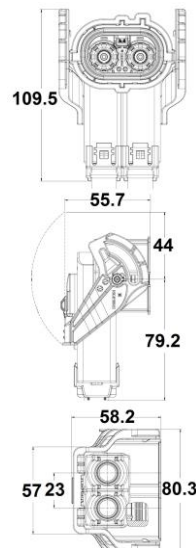
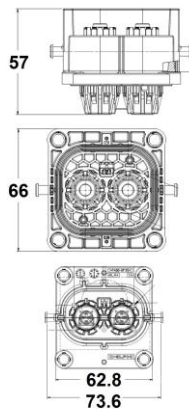

Header connector Part number

Part Number	Description	BOM
35166503	AK 2 Way Pin Header-Code A UL HB	1
35166504	AK 2 Way Pin Header-Code B UL HB	
35166505	AK 2 Way Pin Header-Code C UL HB	
35166506	AK 2 Way Pin Header-Code D UL HB	
33351454	AK 2 Way Pin Header-Code A UL VO	
33351455	AK 2 Way Pin Header-Code B UL VO	

HVIL terminal (Interlock)

Part Number	Description	BOM
14187603	MCON 1.2 Male terminal	2

Female Connector

Part Number	Description	BOM
33355781	AK Class 4 female Code A	1
33355782	AK Class 4 female Code B	
33355783	AK Class 4 female Code C	
33355784	AK Class 4 female Code D	

Associated Components

Part Number	Description	BOM
35172730	Outer insulation	2
35172744	Active Female Terminal	2

25 mm²

Part Number	Description	BOM
35172741	Crimp Female Terminal 25mm	2
35172724	Inner Ferrule 25mm ²	2
35172727	Outer Ferrule 25mm ² - Ni plated	2
35172735	ASM Strain Relief 25 mm ²	2
35172732	Cable Seal 25mm ²	2

35 mm²

Part Number	Description	BOM
35172742	Crimp Female Terminal 35/50mm ²	2
35172725	Inner Ferrule 35mm ²	2
35172728	Outer Ferrule 35mm ² ,Ni plated	2
35172736	ASM Strain Relief 35 mm ²	2
35172733	Cable Seal 35mm ²	2

50 mm²

Part Number	Description	BOM
35172742	Crimp Female Terminal 35/50mm ²	2
35172726	Inner Ferrule for 50mm ²	2
35172729	Outer Ferrule 50mm ² ,Ni plated	2
35172737	ASM Strain Relief 50 mm ²	2
35172734	Cable Seal 50mm ²	2

RCS800 High Voltage

2 Way Connection System with HVIL

APPLICATION

- High voltage/high current modules: inverter, battery, junction box, power electric box

DESCRIPTION

- Bundle shielding with external braid
- Dual sealing connection system: mated and unmated header
- Panel mount to device with face seal to module
- Unique integrated electric interlock
- HVIL shunted in harness connector
- Two-stage disconnect for safe unmating
- ErgoMate™ Axial Mating Assist System on harness connector
- connector
- Two HV power circuits (8.0 mm round terminal)
- Cable range: 35 to 50 mm² power circuit; 0.5 to 0.75 mm²
- Sealing protection: IP67, IPX9K
- Electrical protection: Finger-proof IP2XB

Performance

230A@70C

1000V DC

Temperature

T3

Vibration

V1

Sealing

S3

Dimensions

Shown in millimeters

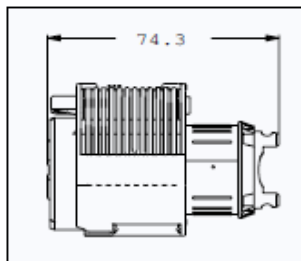
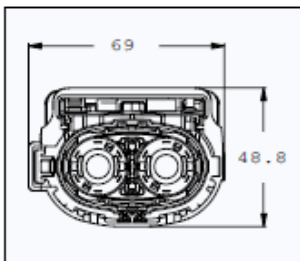
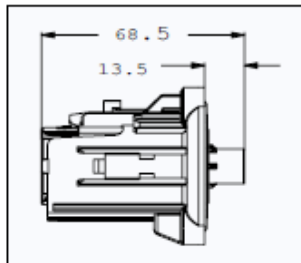
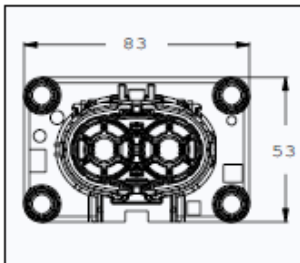

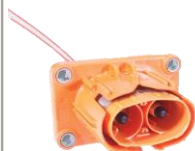

Header connector Part number

Part Number	MPN	Key/index	Description	BOM
33511764	F473110	1	RCS-800 2 way header Code 1 Black	1
33511762	F573110	2	RCS-800 2 way header Code 2 Brown	

Male Terminals

Part Number	MPN	Description	BOM
33512193	F076600	RCS 800 male Bus Bar Terminal Silver version standard length	2
33511746	F176600	RCS 800 male Bus Bar Terminal Silver version V1 length	
33511747	F276600	RCS 800 male Bus Bar Terminal Silver version V2 length	2
10779703	60100734	HVIL- Interlock DCS2 1.5 gold-plated male terminal 0,5-1,0 mm ²	

Seal

Part Number	MPN	Description	BOM
15441379	60993913	DCS 1.5 male Red SWS 0,22 - 0,5 mm ²	2
15441380	60993928	DCS 1.5 male Grey SWS 0,75 - 1,0 mm ²	

Mating Part number



Part Number	MPN	Key/index	Description	BOM
13974469	F673110	1	RCS-800 2WAY plug Code 1 Black	2
33511761	F773110	2	RCS-800 2WAY plug Code 2 Brown	

Female Terminals

Part Number	MPN	Description	BOM
13893887	F385400	RCS 800 female terminal silver version 35 to 50 mm ²	2
13893889	F527600	RCS 800 female retainer (plug)	2

Seal

Part Number	MPN	Description	BOM
13893888	F427600	RCS 800 FEMALE SWS 35-40 MM ² (Plug)	2
13923559	F327600	RCS 800 FEMALE SWS 50 MM ² (Plug)	

RCS890 High Voltage

2 Way Right Angle Connection System with HVIL

APPLICATION

- High voltage/high current modules: inverter, battery, junction box, power electric box

DESCRIPTION

- Bundle shielding with external braid
- Dual sealing connection system: mated and unmated header
- Panel mount to device with face seal to module
- HVIL shunted in harness connector
- Two-stage disconnect for safe unmating
- Slider Mating Assist System on harness connector
- Two HV power circuits (8.0 mm round terminal)
- Flange size: 51 mm x 62 mm
- Cable range: 35 to 50 mm² power circuit; 0.5 to 0.75 mm² HVIL
- Sealing protection: IP67, IPX9K
- Electrical protection: Finger-proof IP2XB

Performance

220A@70C

1000V DC

Temperature

T3

Vibration

V2

Sealing

S3

Dimensions

Shown in millimeters

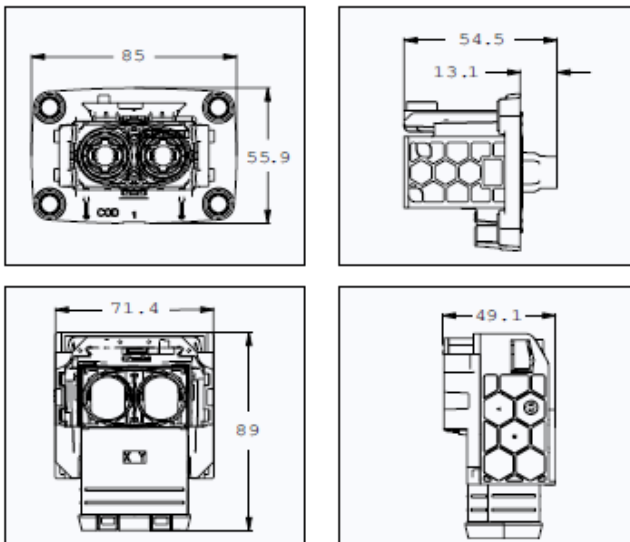



Header connector Part number

Part Number	MPN	Key/index	Description	BOM
33503821	F722210	1	RCS-890 2-Way Header Code 1 Black	1

Male Terminals

Part Number	MPN	Description	BOM
33512193	F076600	RCS 800 Male Bus Bar Terminal Silver version standard length	2
33511746	F176600	RCS 800 Male Bus Bar Terminal Silver version V1 length	
33511747	F276600	RCS 800 Male Bus Bar Terminal Silver version V2 length	
10811962	60001534	DCS2 1.5 gold-plated Female Terminal 0.5 to 1.0 mm ²	2

Seal

Part Number	MPN	Description	BOM
15441379	60993913	DCS 1.5 Male red SWS 0,22 - 0,5 mm ²	2
15441380	60993928	DCS 1.5 Male grey SWS 0,75 - 1,0 mm ²	



Mating Part number

Part Number	MPN	Key/index	Description	BOM
33511750	F922210	1	RCS-890 2-way Plug Code 1 Black	1

Female Terminals

Part Number	MPN	Description	BOM
33502217	F601010	RCS 890 Female Terminal silver version 35 to 50 MM ²	2

Seal & Retainer

Part Number	MPN	Description	BOM
33511754	F232210	RCS 890 2-way Female SWS & Retainer (PLUG) 50 mm ²	2
33511753	F132210	RCS 890 2-way Female SWS & Retainer (PLUG) 35-40 mm ²	

Clamp

Part Number	MPN	Description	BOM
33504038	F825010	RCS890 2-way Half Clamp	2

AK Plastic pass-through

1, 2 & 3 way Panel Mount System

APPLICATION

- High voltage/high current modules: inverter, battery, junction box, power electric box

DESCRIPTION

- Possible configurations: 1, 2 or 3 ways
- Main Housing Material: Plastic
- Terminal Size/Style: Ring-Tongue
- Wire range: 16mm² to 50mm²
- Shielding principle: 360° Individually Shielded

Performance

200A@140C

1000V DC

Temperature

T4

Vibration

V3

Sealing

S3

Dimensions

Shown in millimeters

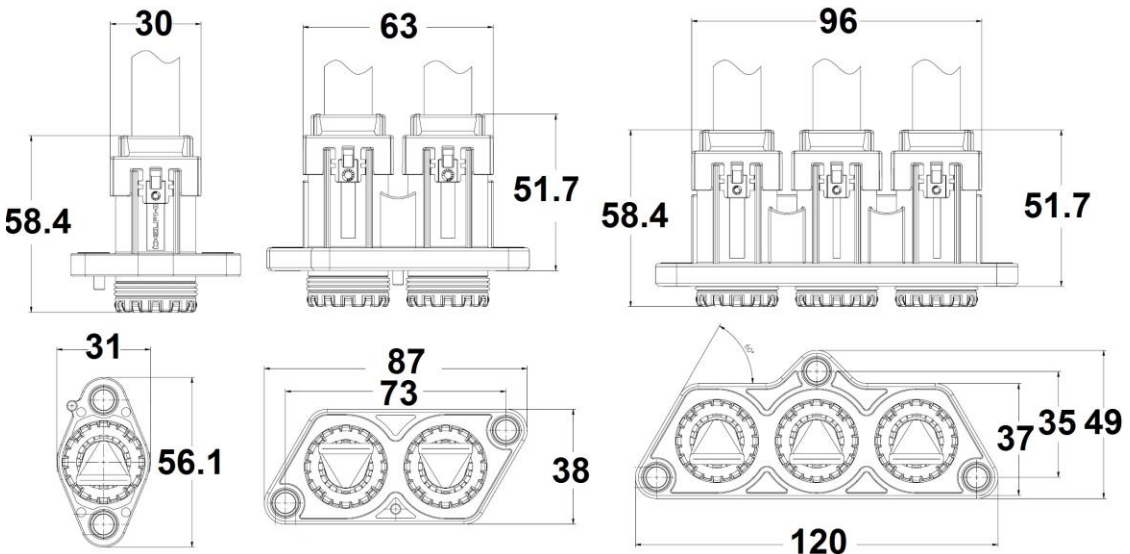

Housing Body Component



Part Number	Description	BOM
33340524	ASM AK pass-through 1-way Code A	1
35066699	ASM AK pass-through 1-way Code B	
33340525	ASM AK pass-through 2-way	
33340526	ASM AK pass-through 3-way	
35116341	Peripheral Seal	1, 2 or 3
35172747	ASM Shielding Inner Ferrule	1, 2 or 3

16 mm²

Part Number	Description	BOM
33340537	Single Wire Seal for 16 mm ² cable	1, 2 or 3
33340542	Protection Cover Assembly for 16mm ²	1, 2 or 3
33340554	Shielding Outer Ferrule for 16 mm ² cable	1, 2 or 3

25 mm²

Part Number	Description	BOM
35172739	Single Wire Seal for 25 mm ² cable	1, 2 or 3
33340541	Protection Cover Assembly for 25mm ²	1, 2 or 3
35172745	Shielding Outer Ferrule for 25 mm ² cable	1, 2 or 3

35 mm²

Part Number	Description	BOM
35172738	Single Wire Seal for 35 mm ² cable,	1, 2 or 3
33340540	Protection Cover Assembly for 35mm ²	1, 2 or 3
35172743	Shielding Outer Ferrule for 35 mm ² cable	1, 2 or 3

50 mm²

Part Number	Description	BOM
33340534	Single Wire Seal for 50 mm ² cable,	1, 2 or 3
33340539	Protection Cover Assembly for 50 mm ²	1, 2 or 3
33340551	Shielding Outer Ferrule for 50 mm ² cable	1, 2 or 3

Metal pass-through

1 way Panel Mount System

APPLICATION

- High voltage/high current modules: inverter, battery, junction box, power electric box

DESCRIPTION

- High voltage panel mount system
- One way sealed and shielded
- Ring terminal bolted to device
- Cable range: 25 to 50 mm²
- Six to eight keys/indexes depending on wire sections
- Very compact dimensions
- Robust design for harsh environment

Performance

250A@85C

1000V DC

Temperature

T3

Vibration

V4

Sealing

S3

Dimensions

Shown in millimeters

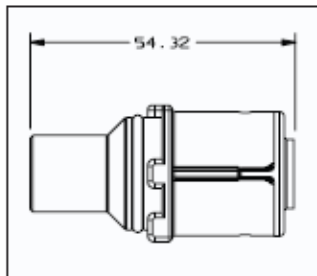
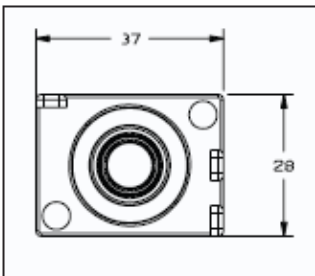

25 mm² Metal pass-through Part Number



Part Number	Key/index	Description	BOM
13888001	102	Metal pass-through 25 mm ²	1
13888002	103	Metal pass-through 25 mm ²	
13888003	104	Metal pass-through 25 mm ²	
13888004	105	Metal pass-through 25 mm ²	
33253253	108	Metal pass-through 25 mm ²	
33253254	109	Metal pass-through 25 mm ²	

Accessories

13888023		25 mm ² Seal retainer	1
13888030		25 mm ² Seal	1
13888025		O-ring Seal	1
33295901		25 mm ² Ferrule	1

35 mm² Metal pass-through Part Number

Part Number	Key/index	Description	BOM
13894189	102	Metal pass-through 35 mm ²	1
13894190	103	Metal pass-through 35 mm ²	
13894191	104	Metal pass-through 35 mm ²	
13894192	105	Metal pass-through 35 mm ²	
33253255	108	Metal pass-through 35 mm ²	
33253256	109	Metal pass-through 35 mm ²	

Accessories

13894241		35 mm ² Seal retainer	1
33288396		35 mm ² Seal	1
13888025		O-ring Seal	1
33295902		35 mm ² Ferrule	1

50 mm² Metal pass-through Part Number

Part Number	Key/index	Description	BOM
33112598	102	Metal pass-through 50 mm ²	1
33112599	103	Metal pass-through 50 mm ²	
33112600	104	Metal pass-through 50 mm ²	
33112601	105	Metal pass-through 50 mm ²	
33112602	106	Metal pass-through 50 mm ²	
33112608	107	Metal pass-through 50 mm ²	
33112609	108	Metal pass-through 50 mm ²	
33112610	109	Metal pass-through 50 mm ²	



Accessories

33112613		50 mm ² Seal retainer	1
33112616		50 mm ² Seal	1
13888025		O-ring Seal	1
33295903		50 mm ² Ferrule	1



Selector Guide

12, 24 and 48 Volt Solutions

Image	Page #	Application	Description	Temperature Vibration Class	Shielding	Amperage	Voltage	# Ways orientation	Sections
	36-37		Power Pack 1000 1way Inline Connectors						
	38-39	High current module mates Electrical center mate Front Wall/Sheet metal Power Pass-through Electric Power Steering High Current inline	Power Pack 1000 2way Device Connector with straight and right angle Exit	T3 V1	No	145A at 85°C	12 to 48V	1 to 2 ways / 90° & 180°	8 to 25 mm ²
	40-41		Power Pack 1000 2way Inline Connectors						

Power Pack 1000

1 Way Inline Connectors

APPLICATION

- High current wiring harness inline

DESCRIPTION

- Sealed connection system
- Silver-plated Power Pack1000 multi-contact terminal system
- Cable range: 8 mm² to 25 mm²
- One key/index
- Capable of additional indexes

Performance

145A@85C

48V

Temperature T3

Vibration V1

Sealing S3

Dimensions

Shown in millimeters

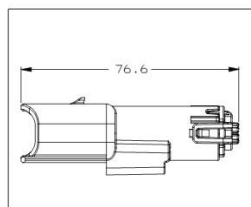
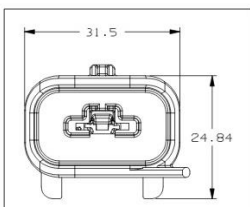
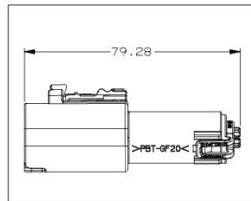
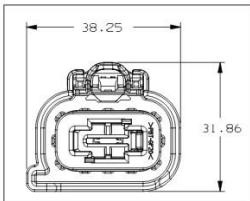



Male Connector Part number

Part Number	Description	BOM
13882980	Power Pack 1000 male in-line connector	1

Male Terminal Part Number

Part Number	Description	BOM
13675577	PP1000 Male Silver Terminal 8-10 mm ²	1
13675579	PP1000 Male Silver Terminal 19-25 mm ²	

Cable Seal

Part Number	Description	BOM
13675510	Cable seal PP1000 4.54 - 5.79 dia cable (Grey) (8-10mm ²)	1
13675513	Cable seal PP1000 4.54 - 5.79 dia cable (Blue) (19-25mm ²)	

Cable Seal Retainer

Part Number	Description	BOM
13849785	Cable seal retainer PP1000 (8-10mm ²)	1
13849788	Cable seal retainer PP1000 (19-25mm ²)	

Mating Part number

Part Number	Description	BOM
13952702	Power Pack 1000 female in-line connector	1

Female Terminal Part Number



Part Number	Description	BOM
13675583	PP1000 Female Silver Terminal 8-10 mm ²	1
13675585	PP1000 Female Silver Terminal 19-25 mm ²	

Cable Seal

Part Number	Description	BOM
13675510	Cable seal PP1000 4.54 - 5.79 dia cable (gray) (8-10mm ²)	1
13675513	Cable seal PP1000 4.54 - 5.79 dia cable (blue) (19-25mm ²)	

Cable Seal Retainer

Part Number	Description	BOM
13849785	Cable seal retainer PP1000 (8-10mm ²)	1
13849788	Cable seal retainer PP1000 (19-25mm ²)	

Power Pack 1000

2 Way Device Connectors

APPLICATION

- High current device applications and sealed pass-through panel mount system

DESCRIPTION

- Sealed connection system
- Sealed panel mount pre-stages prior to fastening through self tapping screws
- Silver-plated Power Pack 1000 multi-contact terminal system
- Cable range: 8 mm² to 25 mm²

Performance

145A@85C

48V

Temperature T3

Vibration V1

Sealing S3

Dimensions

Shown in millimeters

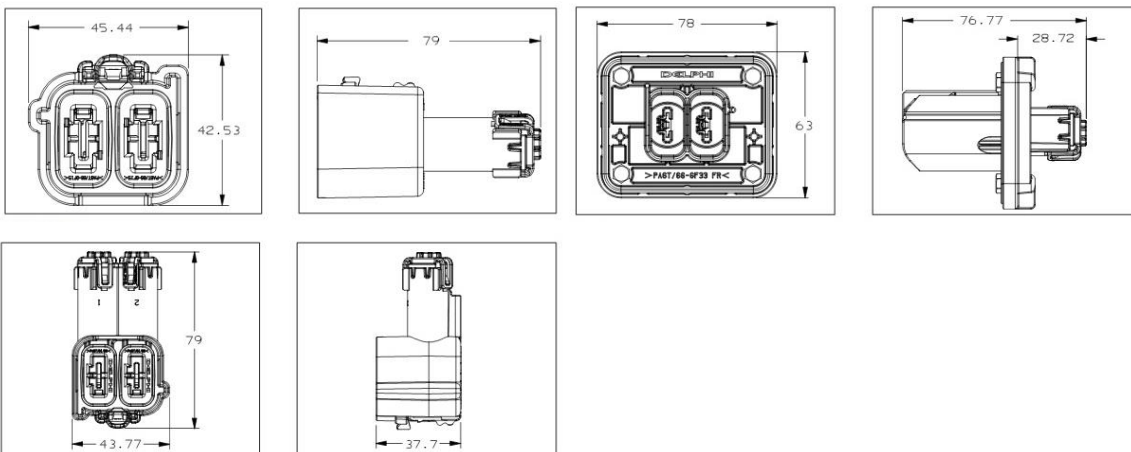

Header Connector Part number – Straight Exit



Part Number	Description	BOM
13959822	Power Pack 1000 male header connector – Straight exit	1
13675577	PP1000 Male Silver Terminal 8-10 mm ²	2
13675579	PP1000 Male Silver Terminal 19-25 mm ²	

Header connector Part number - Right angle exit



Part Number	Description	BOM
13599824	Power Pack 1000 male header connector – Right angle exit	1
13675577	PP1000 Male Silver Terminal 8-10 mm ²	2
13675579	PP1000 Male Silver Terminal 19-25 mm ²	

Cable Seal

Part Number	Description	BOM
13675510	Cable seal PP1000 4.54 - 5.79 dia cable (gray) (8-10mm ²)	2
13675513	Cable seal PP1000 4.54 - 5.79 dia cable (blue) (19-25mm ²)	

Cable Seal Retainer

Part Number	Description	BOM
13849785	Cable seal retainer PP1000 (8-10mm ²)	2
13849788	Cable seal retainer PP1000 (19-25mm ²)	

Mating Part number – Straight Exit



Part Number	Description	BOM
13849756	Power Pack 1000 female straight exit	1
13675583	PP1000 Female Straight Silver Terminal 8-10 mm ²	2
13675585	PP1000 Female Straight Silver Terminal 19-25 mm ²	

Mating Part Number – Right Angle Exit



Part Number	Description	BOM
13849758	Power Pack 1000 female right angle exit	1
13675587	PP1000 Female Right angle Silver Terminal 8-10 mm ²	2
13675590	PP1000 Female Right angle Silver Terminal 19-25 mm ²	

Cable Seal

Part Number	Description	BOM
13675510	Cable seal PP1000 4.54 - 5.79 dia cable (gray) (8-10mm ²)	2
13675513	Cable seal PP1000 4.54 - 5.79 dia cable (blue) (19-25mm ²)	

Cable Seal Retainer

Part Number	Description	BOM
13849785	Cable seal retainer PP1000 (8-10mm ²)	2
13849788	Cable seal retainer PP1000 (19-25mm ²)	

Power Pack 1000

2 Way inline Connectors

APPLICATION

- High current wiring harness inline

DESCRIPTION

- Sealed connection system
- Silver-plated Power Pack 1000 multi-contact terminal system
- Cable range: 8 mm² to 25 mm²
- One key/index

Performance

145A@85C

48V

Temperature T3

Vibration V1

Sealing S3

Dimensions

Shown in millimeters

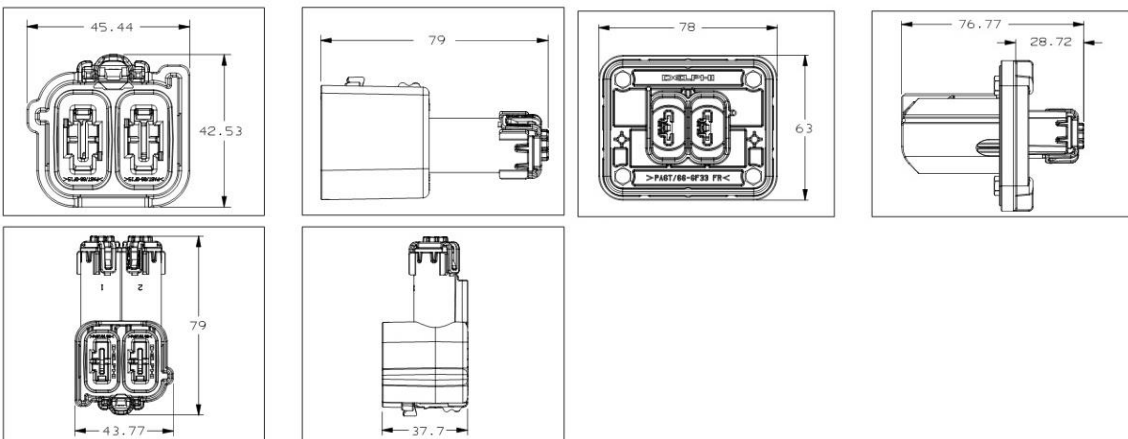



Male Connector Part number

Part Number	Description	BOM
13849747	Power Pack 1000 male header connector – Straight exit	1
13675577	PP1000 Male Silver Terminal 8-10 mm ²	2
13675579	PP1000 Male Silver Terminal 19-25 mm ²	

Cable Seal

Part Number	Description	BOM
13675510	Cable seal PP1000 4.54 - 5.79 dia cable (gray) (8-10mm ²)	2
13675513	Cable seal PP1000 4.54 - 5.79 dia cable (blue) (19-25mm ²)	

Cable Seal Retainer

Part Number	Description	BOM
13849785	Cable seal retainer PP1000 (8-10mm ²)	2
13849788	Cable seal retainer PP1000 (19-25mm ²)	



Mating Part Number

Part Number	Description	BOM
13849756	Power Pack 1000 female straight exit	1
13675583	PP1000 Female Straight Silver Terminal 8-10 mm ²	2
13675585	PP1000 Female Straight Silver Terminal 19-25 mm ²	

Cable Seal

Part Number	Description	BOM
13675510	Cable seal PP1000 4.54 - 5.79 dia cable (grey) (8-10mm ²)	2
13675513	Cable seal PP1000 4.54 - 5.79 dia cable (blue) (19-25mm ²)	

Cable Seal Retainer

Part Number	Description	BOM
13849785	Cable seal retainer PP1000 (8-10mm ²)	2
13849788	Cable seal retainer PP1000 (19-25mm ²)	



Selector Guide

Charging Solutions

Image	Page #	Application	Description	Design Life	Phase	Amperage	Voltage	Wire Selections/ cable length
	44-45	Plug-in hybrid and electric vehicle AC charge inlet (Male)	SAE J1772, Type I Vehicle Charging Inlet	10,000 + Mating cycles	1 Phase	15A 30A	120V 240V	2 to 5 mm ²
	46-47	Plug-in hybrid and electric vehicle AC charge inlet (Male)	IEC62196 type II Vehicle Charging Inlet	10,000 + Mating cycles	1 Phase 3 Phase	16A 63A	230V 480V	2.5 to 16 mm ²
	48-49	Charging interface for slow AC (Type 1) and fast DC charging applications	Combo 1 AC/DC Vehicle Charging Inlet	10,000 + Mating cycles	1 Phase	32A	120V 240V	6 mm ²
	50-51	Charging Interface for slow AC (Type II) and fast DC charging applications	Combo 2 AC/DC Vehicle Charging Inlet	10,000 + Mating cycles	1 Phase 3 Phase	16A 32A	240V	4 mm ²
	52-53	Cable assemblies for integration into charging stations (female) Type 1 (NA) Type 2 (EMEA)	Charge Connector - Pigtails	10,000 + Mating cycles	1 Phase 1 Phase 1 & 3 Phase 1 Phase 1 & 3 Phase	16A 18A 20A 25A 32A	120V – 480V	5 to 7 mm ²
	54	Charging between Vehicle and Charge Station Type 2 to Type 2 Type 1 to Type 2 Type 1 to Type 3	Charge Connectors Mode 3 Jumpers	10,000 + Mating cycles	3 Phase 1 Phase 1 Phase 1 Phase	20A (T2-T2) 32A (T2-T2) 20A (T1-T2) 32A (T1-T2) 20A (T1-T3)	120V - 240V	4 to 6.5 m
	55	Portable Electric Vehicle Supply Equipment (EVSE) for electric vehicle charging (female)	Charge Coupler Connector mode 2 assembly (with ICCB)	10,000 + Mating cycles	1 Phase	8A - 10A	120V- 240V	5m

Charge Inlet

SAE J1772 Type 1 Vehicle Charging Inlet

APPLICATION

- Plug-in hybrid and electric vehicle charge inlet

DESCRIPTION

- Interface complies with SAE J1772 and IEC62196 Type I standard
- Panel mounts to vehicle
- Protective grommet/wire dress mounts to inlet

PERFORMANCE

- Supports: AC Level 1 (15A, 120V) and AC Level 2 (32A, 240V)
- Voltage: 600V maximum rating
- Temperature range: -40°C to +85°C
- Validation: UL recognized
- Electrical protection: Finger-proof IP2XB
- Design life: 10,000 mating cycles

Dimensions

Shown in millimeters

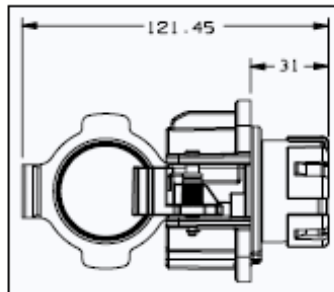
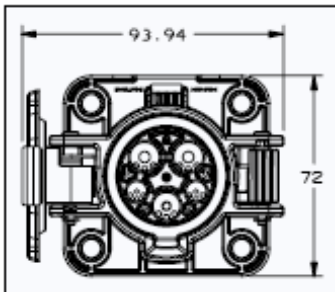



Part number

Part Number	Description	BOM
13826395	Cover opens left	1

Grommet

Part Number	Description	BOM
13826280	Grommet wire protection	1

TPA

Part Number	Description	BOM
13826277	TPA	1

Terminals

Part Number	Description	AWG Gauge	Wire section mm ²	BOM
13884348	1.5mm pin	18 GA (0.8-0.75 mm ²)	0.75 mm ²	2
13884350	2.8mm pin	14 GA (2-2.5 mm ²)	2.5 mm ²	1
13884351	2.8mm pin	10 GA (5 mm ²)	5 mm ²	1
13884352	3.6mm pin	14 GA (2-2.5 mm ²)	2.5 mm ²	2
13884353	3.6mm pin	10 GA (5 mm ²)	5 mm ²	2

Charge Inlet

Type II Vehicle Charging Inlet

APPLICATION

- Plug-in hybrid and electric vehicle charge inlet

DESCRIPTION

- Interface complies with IEC62196 Type II standard
- Panel mounts to vehicle
- Integrated thermal circuit breaker to prevent abnormal temperature increase
- Cover provides dust protection
- Inlet designed to drain fluids when opened
- Lock actuator positioned on the top
- Available with cover opening right or left

PERFORMANCE

- Supports single-phase or three-phase power supply
- Supports: From 16A, 230V to 63A, 400V
- Temperature range: -40°C to +50°C
- Electrical protection: Finger-proof IP2XB
- Sealing protection: IP44 (connector/inlet mated)
- Wiring crimps sealed from environment
- Design life: 10,000+ mating cycles

Dimensions

Shown in millimeters

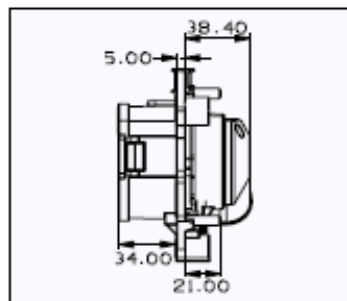
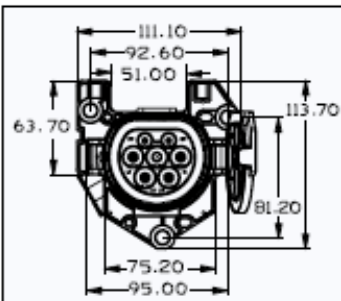



Part number

Part Number	Description	BOM
33402098	Inlet sub-assy - INLET Type II Right open cover, Left wire exit	1
33400030	Rear Cover, Left wire exit	1
33402097	Inlet sub-assy - INLET Type II Left open cover, Right wire exit	1
33400076	Rear Cover ,Right wire exit	1

Grommet

Part Number	Description	BOM
33401379	Rear grommet tube	1

TPA

Part Number	MPN	Description	BOM
33508692	F501410	TPA	1

Screw

Part Number	MPN	Description	BOM
33514388	F028010	Screw	3

Thermo sensor

Part Number	MPN	Description	BOM
33514398	F373410	Thermo sensor set	1 (see note)

Terminals for 16A version (1-ph)

Part Number	MPN	Designation	Wire section	BOM (1-phase)
33267394	NA	Male terminal 6mm diameter with cap Ag - N & L1	2.5 mm ²	2
33513981	F632410	Male terminal 6mm diameter w/o cap Ni - PE	2.5 mm ²	1
33502256	F832410	Male terminal 3mm diameter - 13mm length - CP	0.5 mm ²	1
33502238	F732410	Male terminal 3mm diameter - 25mm length - PP	0.5 mm ²	1

Terminals for 32A version (1-ph or 3-ph)*

Part Number	MPN	Designation	Wire section	BOM (1-phase)	BOM (3-phase)
33403032	NA	Male terminal 6mm diam with cap Ag - N,L1,L2 & L3	6 mm ²	2	4
33403033	NA	Male terminal 6mm diam w/o cap Ag - PE	6 mm ²	1	1
33502256	F832410	Male terminal 3mm diameter - 13mm length -CP	0.5 mm ²	1	1
33502238	F732410	Male terminal 3mm diameter - 25mm length - PP	0.5 mm ²	1	1

Terminals for 63A version (1-ph or 3-ph)*

Part Number	MPN	Designation	Wire section	BOM (1-phase)	BOM (3-phase)
33267396	NA	Male terminal 6mm diam with cap Ag - L1,L2 ,L3,N	16 mm ²	2	3 or 4
33267394	NA	Male terminal 6mm diameter with cap Ag - N	4 mm ²		1 or 0
33267382	NA	Male terminal 6mm diameter w/o cap Ag - PE	16 mm ²	1	1
33502256	F832410	Male terminal 3mm diameter - 13mm length -CP	0.5 mm ²	1	1
33502238	F732410	Male terminal 3mm diameter - 25mm length - PP	0.5 mm ²	1	1

* Compulsory usage of thermo sensor set

Combo 1

AC/DC Vehicle Charging Inlet

APPLICATION

- Charging interface for slow AC (Type 1) and fast DC charging applications

DESCRIPTION

- Interface complies with SAE J1772 and IEC62196
- Combined charging system for electrical vehicle
- AC/DC: slow + fast charge (600V, 125A)
- Actuator pin for locking connector to inlet during charging
- Optional thermistor for additional thermal protection during DC charging
- Wire Cross Section: Contact Pin/Present Pin (0.5 mm²), PE (16mm², L1/N (6.0 mm²), DC +/- (40 mm²)

PERFORMANCE

- Temperature range: -40°C to +80°C
- Voltage: 600V
- Max. current capacity: 32A AC/ 125A DC
- Sealing protection: IP55 with cover, IP44 when mated
- Connector/Inlet mating and unmating force <100N
- Design life: 10,000+ mating cycles

Dimensions

Shown in millimeters

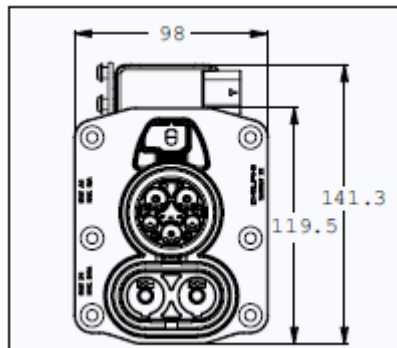
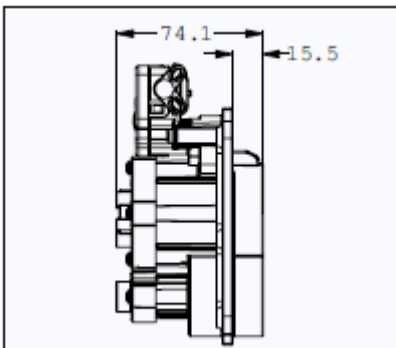



Housing Part number

Part Number	Description	BOM
33133127	Main Housing	1

Components and Accesories

Part Number	Description	BOM
33133129	AC Back Cover	1
33133126	AC Block Seal Cable (6mm ² cable)	1
33133116	AC Block Seal Terminal	1
33133128	DC Back Cover	1
33133115	DC Block Seal Cable	1
33133108	DC Retainer	1
33103899	DC O-Ring	2
33133132	AC Retainer	1
15532546	Screw	7

Actuator and Seals

Part Number	Description	BOM
33235151	Actuator Combo 1	1
33133105	Block Seal for Actuator	1

Dust Caps

Part Number	Description	BOM
33133134	Dust Caps	1

Terminals

Part Number	Description	BOM
15522876	Ø 3.6 mm - 6mm ² cable cross section (AC Power N, L1, L2 with protection cap)	2
15522875	Ø 2.8mm - 16 mm ² cable cross section (Ground)	1
13884348	Ø 1.5 mm (Pilot)	2
15522877	Ø 8.0 mm – 35 mm ² (DC Power)	2

Combo 2

AC/DC Vehicle Charging Inlet

APPLICATION

- Charging interface or slow AC (Type 11) and fast DC charging applications

DESCRIPTION

- Interface complies with IEC62196
- Combined charging system for electrical vehicle
- AC/DC: slow + fast charge (600V, 125A)
- Actuator pin for locking connector to inlet during charging
- Optional thermistor for additional thermal protection during DC charging
- Wire Cross Section: Contact Pin/Present Pin (0.5 mm²), PE (16mm², L1/N (6.0 mm²), DC +/- (40 mm²)

PERFORMANCE

- Temperature range: -40°C to +80°C
- Voltage: 600V
- Max. current capacity: 32A AC/ 125A DC
- Sealing protection: IP55 with cover, IP44 when mated
- Connection/Inlet mating and unmating force <100N
- Design life: 10,000+ mating cycles

Dimensions

Shown in millimeters

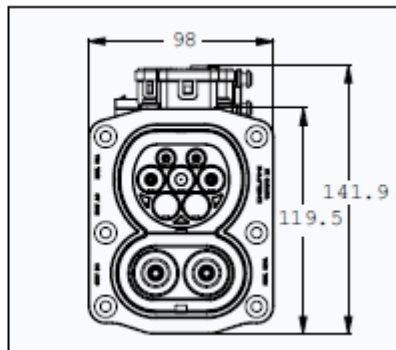
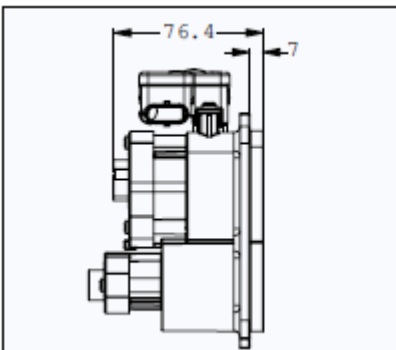



Housing Part number

Part Number	Description	BOM
33265593	Main Housing	1

Components and Accesories

Part Number	Description	BOM
33265597	AC Back Cover	1
33265958	AC Block Seal Cable (4mm ² cable)	1
33265598	AC Retainer	1
33265965	AC Block Seal Terminal	1
33133855	DC Back Cover	1
33133931	DC Block Seal Cable	1
33133859	DC Retainer	1
33103899	DC O-Ring	2
15532546	Screw	7

Actuator and Seals

Part Number	Description	BOM
10808197	Actuator Combo 2	1
33133105	Block Seal for Actuator	1

Dust Caps

Part Number	Description	BOM
33134019	Dust Caps	1

Terminals

Part Number	Description	BOM
33133795	Ø 6 mm - 4 mm ² cable cross section (AC Power with protection cap)	2 or 4
15522870	Ø 6 mm – 16 mm ² cable cross section (PE / Ground)	1
33133789	Ø 3 mm (PP / Pilot)	1
33133739	Ø 3 mm ² (CP / Pilot)	1
33133788	Ø 8.0 mm – 35 mm ² (DC Power)	2

Device for Multicore to Individual Cables (Optional)

Part Number	Description	BOM
33265973	Tube	1
33265971	Front TPA	1
33265972	Back TPA	1
33265947	Power cable Seal	1
33265941	Power cable Blockseal	1

Charge Connectors

Pigtails

APPLICATION

- Grid-to-vehicle charging
- Charging infrastructure-to-vehicle

DESCRIPTION

- SAE J1772/IEC62196 Type I, IEC62196 Type II, and GB/T 20234 standards
- Wiring crimps sealed from environment
- Rubber over-mold and plastic grip options available

PERFORMANCE

- Current capacity: 18A to 40A
- Voltage range: 120V to 480V
- Temperature range: -40°C to +50°C
- Validation: See part number information



SAE J1772/IEC62196 Type I – Plastic Handle



IEC62196 Type II – Plastic Handle



SAE J1772/IEC62196 Type I – Rubber Over Mold



IEC62196 Type II – Rubber Over Mold

Part Number	Type (veh/wall)	Current	# phase	Design	cable length (m/ft)	Cable sections	Certification	Manufacturing plant
33248422	Type 1 / SAE J1772	18 A	1-phase	Plastic handle	7.0/23	3G AWG 14 + 0.8	UL	North America
33248425	Type 1 / SAE J1772	25 A	1-phase	Plastic handle	7.6/25	3G AWG 12 + 0.8	UL	North America
35078184	Type 1 / SAE J1772	40 A	1-phase	Plastic handle	7.6/25	3G AWG 10 + 0.8	UL	North America
33155748	Type 1	20A	1-phase	Rubber over mold	5.0 / 16.40	3G2.5+0.5	CE	Europe
33155747	Type 2	20A	1-Phase	Rubber over mold	5.0 / 16.40	3G2.5+0.5	CE	Europe
33155746	Type 2	20A	3-Phase	Rubber over mold	5.0 / 16.40	5G2 +0.5	CE	Europe
33155745	Type 2	32A	3-phase	Rubber over mold	5.0 / 16.40	5G6 +0.5	CE	Europe
33502596	Type 2	16A	1-phase	Plastic handle	6.5 / 21.32	3G2.5 +0.75	CE	Europe
33507943	Type 1 cap							Europe
15527767	Type 2 cap							Europe

Charge Plug

Mode 3 Jumpers

APPLICATION

- Cable assemblies for plugging from charging station to vehicle

DESCRIPTION

- Vehicle to charging station connection
- Vehicle connector according to IEC62196-2-1 and IEC62196-2-2
- Wiring crimps sealed from environment
- CE marking

AVAILABLE OPTIONS

- 20 to 32A
- 1-phase 240V or 3-phase 400V charging for Type II
- Superior durability: 14,000 cycles (10,000 cycles is required from IEC standard)
- Low mating / unmating forces: Initial < 40N, Mating forces < 80N guaranteed until 14,000 cycles



Type I to Type II – Plastic Handle



Type II to Type II – Plastic Handle



Type I to Type III – Plastic Handle

Part number	Type (veh / wall)	Current	# phase	Design	cable length (m/ft)	Cable sections	Marking	Manufacturing plant
33358146	Jumper T2 -T2	20A	3-phase	All plastic grip	6.5 / 21.32	5G4+0.75	CE	Europe
35137656	Jumper T2 -T2	32A	3-phase	All plastic grip	4.0 / 13.12	5G4+0.75	CE	Europe
35141693	Jumper T2 -T2	32A	3-phase	All plastic grip	6.5 / 21.32	5G4+0.75	CE	Europe
33401184	Jumper T1 -T2	20A	1-phase	All plastic grip	6.0 / 19.68	3G2.5+0.75	CE	Europe
33403378	Jumper T1 -T2	32A	1-phase	All plastic grip	6.0 / 19.68	3G6+0.75	CE	Europe
33401185	Jumper T1 -T3	20A	1-phase	All plastic grip	6.0 / 19.68	3G2.5+0.75	CE	Europe

Charge plug mode 2 assembly (with ICCB) Generation II

APPLICATION

- Portable Electric Vehicle Supply Equipment (EVSE) for grid-to-vehicle charging

DESCRIPTION

- Vehicle interface according to IEC62196-2-2
- EVSE provides restart in the event of power grid fault
- Product according to the new IEC62752 standard including Type B RCD and residential DC current detection
- CE Marking
- Control box has higher water sealing protection than the standard: IP67
- Dual-thermo sensors in the grid plug provide superior overheating protection



AVAILABLE OPTIONS

- 240V with 6 to 15A (depending on country regulations)
- Grid cord as required by country of use
- Additional country configurations also available

Part Number	Type (veh)	Current	# phase	Design	cable length (m/ft)	Countries	Marking	Manufacturing plant
35054780	Type 2	10A	1-phase	Soft grip	5.0 / 16.40	Europe, Germany	CE	Europe
35086913	Type 2	8A	1-phase	Soft grip	5.0 / 16.40	France, Finland	CE	Europe
35054781	Type 2	10A	1-phase	Soft grip	5.0 / 16.40	UK, Ireland, Cyprus, Malta	CE	Europe
35058252	Type 2	6A	1-phase	Soft grip	5.0 / 16.40	Denmark	CE	Europe
35054782	Type 2	8A	1-phase	Soft grip	5.0 / 16.40	Switzerland	CE	Europe
35054784	Type 2	10A	1-phase	Soft grip	5.0 / 16.40	Norway	CE	Europe
35054788	Type 2	8A	1-phase	Soft grip	5.0 / 16.40	Italy	CE	Europe
35054783	Type 2	15A	1-phase	Soft grip	5.0 / 16.40	Europe - Grid plug CEE 16/3	CE	Europe



For **more** information:

Visit our website: <http://aptiv.com/>

Browse our E-catalog: <http://ecat.aptiv.com/>

Contact your local Distributor



• **APTIV** •