

## RNJ

### Rack & Panel Cylindrical Connectors



# OUR COMPANY



## Proven excellence in interconnect solutions

- Since **1947**, Amphenol Socapex has prescribed, designed and manufactured reliable and innovative interconnection solutions for harsh environments, specializing in standard and customized electrical and fiber optic connectors, contacts, accessories and cabling solutions.
- Located in the **Mont Blanc region** of France and Pune in India, Amphenol Socapex serve customers in over 100 countries around the world.
- Amphenol Socapex is part of the leading supplier of interconnect systems **Amphenol**.



**1400+**  
employees



**175 M€**  
Net Sales 2024  
75% Export - 25% France



Thyez, **France**  
Pune, **India**



## Our expertise has no boundaries

### Integrated Production in France & India

- 24 000 m<sup>2</sup> manufacturing capacity on 2 sites
- Design and manufacturing centers in France and India
- State-of-the-art manufacturing technology

## Our markets



**Defense**



**Commercial  
Aerospace**



**Space**



**Industry**

# TECHNOLOGIES & INNOVATION

## Engineering Laboratory



**Product testing and qualification expertise in many fields:**  
 - Environmental, mechanical, electrical, chemical, climatic skills  
 - RF and fiber optics expertise

## High-Speed Expertise



**Strong expertise in high-speed signals**  
 - 3D EM simulation software & EM models  
 - Time Domain and frequency domain

## Materials Expertise



**Focus on materials expertise and manufacturing techniques to produce faster, smaller and stronger products**  
 - Advanced technology research and development: polymers, metals, platings, resins ...  
 - Cutting edge characterizations of interconnects: Radio Frequency, partial discharges ...  
 - 3D CAD mechanical software, simulation & analysis

## Eco-responsibility



**Sustainable environment approach, with pro-active management of regulations (REACH / RoHS / Conflict minerals...)**  
 - New materials development, plating, and suitable processes  
 - Recycling and rational resources consumption

## Our workshops



Our workshops located in France & India provide consistent quality adapted to your volume requirements.

**Automation & Tooling :** Tools for our different activities : molding, machining, assembly

**Molding :** Solid expertise in thermoplastic elastomer and thermoset molding

**Machining :** Manufacturing of cylindrical shells and rectangular shells

**Screw Machining :** Manufacturing of electrical contacts

**Plating :** Plating with cadmium, nickel, electroless nickel, silver, black zinc nickel, gold

**Assembly :** Connector and harness assembly (electrical & optical)

## Our certifications

Product certifications : MIL-DTL38999, EN3645, EN3155, VG (VG95328, VG95319, VG96944, VG95218, VG96949)



Certified Management System



Certified Management System



Certified Management System



Certified Management System

## Our memberships

Member of CMG (Connecting Manufacturing Group) Consortium



# CUSTOMER EXPERIENCE



## Service

► We have a strong reputation for helping customers solve their toughest challenges. This approach of serving your needs is ingrained in our company - from our sales team to our product development engineers.

## A partner you can trust

### Customer Proximity



### Design Expertise



### Quality Commitment



### On Time Delivery Performance







### Compliance management



## Buy our solutions

You can access our solutions through our global network of sales offices or through our distributors.

### Field Sales Team :

-  10 in France
-  15 in Europe
-  100+ in North America and rest of the world.
-  5 Business Development Managers supporting local sales force Europe, North America and the rest of the world

-  **Technical Advisement & Multilingual Customer Service :**  
20 people

### Worldwide Distribution Network :

Our range of circular connectors, contacts, fiber optic connectors, PCB connectors and accessories are available thru our extensive distribution network.

It includes qualified distributors (QPL approved) for assembling MIL-DTL-38999 & derivatives and PT/451 (VG95328) connectors.

[Check our product inventory](#)



[Product Selectors & 3D Files](#)



NEW



# OUR HISTORY

1947



- **Socapex creation** in Suresnes, France  
- 1<sup>st</sup> radio connector

1956-57



- **Manufacturing unit in Cluses** (74), France  
- Thomson-CSF becomes primary shareholder

Early 1960's



- 1<sup>st</sup> board level connectors: HE8  
- 1<sup>st</sup> "licence Bendix" manufactured connectors  
- SL Series

1973



**New factory in Thyez** (74) France with 250 people, 13 000m<sup>2</sup>

1975

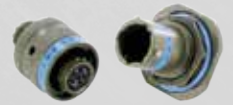

Production of 38999 connectors

1986

**Amphenol Socapex**

**Amphenol** becomes primary shareholder

1995-96



- Expanded Beam connector CTOS launch  
- Headquarters transferred to Thyez

2004



RJ Field launch, "Award Electronica"

2005



**New factory in Pune, India**

2010's



LuxBeam™ and HDAS launch

2014-2017

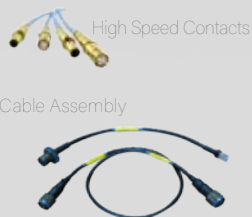

**New workshops :**  
- Cable Assembly & Contact Manufacturing workshop

2019



**Increased manufacturing capacity** with 2<sup>nd</sup> building in Pune, India

2022



Harness in the box solution launch

Today & tomorrow



**New technologies :**  
- Investment in automation & technical expertise



Amphenol SOCAPEX joins the "Convention des Entreprises pour le Climat".  
- Our goal: **to accelerate our transition to a more sustainable operation.**



## RNJ - RACK AND PANEL CYLINDRICAL CONNECTORS

### MAIN CHARACTERISTICS

#### EMI shielding

- Shells are grounded before contact mating
- Lightweight space saving design
- Durability: - 500 cycles
- Moisture resistance: in addition to interfacial seal, main joint souffler and rear gasket on the plug are set up for moisture sealing between connector halves
- Corrosion resistance:
  - Olive drab cadmium over nickel plating on aluminium shell (withstands 500 hours of salt spray exposure) or electroless nickel
  - Free cadmium version also available.
- 8 shell sizes from 11 to 25
- Contact protection:
  - 100% scoop-proof. The design prevents bent pins and a short circuit occurring during mating.
  - Between 1 and 128 contacts in accordance with Mil-C-39029 standard
  - Crimp contacts sizes 22D, 20, 16, 12, 8, 4, 00.
  - PCB contacts sizes 22D & 20 (size 16, 12, 8, please consult Amphenol)
  - Wire-wrap contacts sizes 22D & 20
  - Optical termini (POM series) in accordance with Mil-T-29504 standard
- For environmental applications: - Supplied without rear accessories. Design provides serrations on rear threads of shells.

Compatible with some M 85049 rear accessories for MIL-DTL-38999 I connectors.

Please consult us.

- Temperature range: -65°C +175°C
- Insulation resistance > 5000 Mohms at ambient temperature under 500 Vcc



### DESCRIPTION

The RNJ series rack and panel connectors are qualified for the requirements of the standard DAT C 5935 x 0005 HE308 21, 25, 26 & 27T models. They are used to connect electrical and optical devices between a moving unit (rack) and a fixed unit (panel) without any coupling / uncoupling device. This function is ensured by a system of moving and the fixed units.

The connectors are built to allow for design tolerances (up to the limits shown in figure 1) during the mating of the connectors and the final locking of the moving and fixed units. These connectors are derived from the LJT series and meet or exceed the MIL-DTL-38999 Series I requirements.

### APPLICATIONS

- Military applications & Aeronautic
- Advanced industrial applications

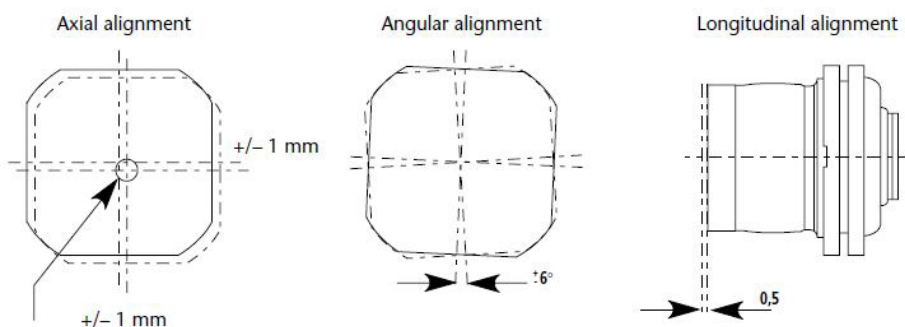

## PRESENTATION

- 1 - Receptacle shell
- 2 - O ring
- 3 - Hexagonal nut
- 4 - Rivet
- 5 - Sealed membrane
- 6 - Free plug shell
- 7 - Fixed plug shell
- 8 - Panel nut (plug)
- 9 - O ring
- 10 - Sealed membrane
- 11 - Grommet
- 12 - Dielectric retention disc
- 13 - Pin contact
- 14 - Male insert
- 15 - Interfacial seal
- 16 - Female insert
- 17 - Grounding fingers
- 18 - Socket contact
- 19 - Spring washers

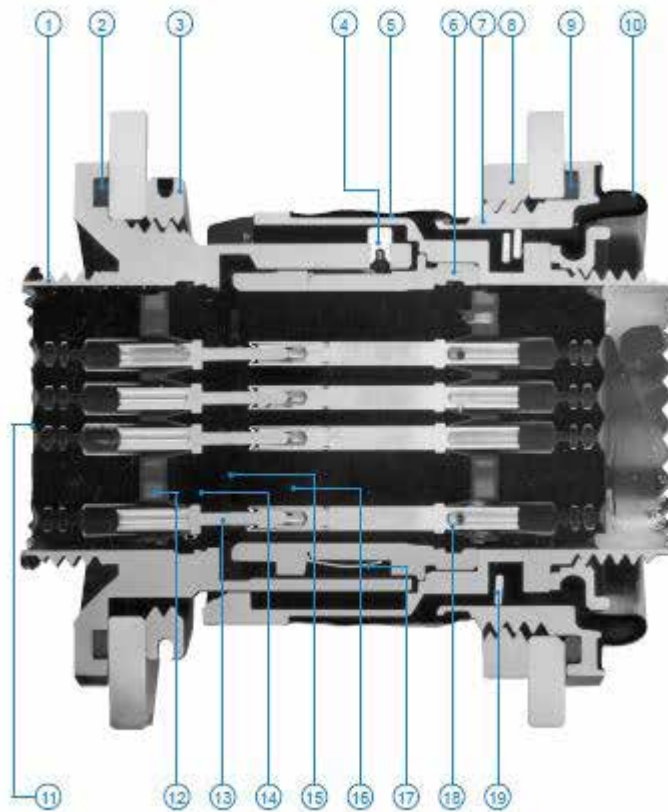

## ENVIRONMENTAL CHARACTERISTICS

Temperature range: -65°C to +175°C

- High temperature endurance 1000 hours
- Humidity 100% R.H.
- Air leakage:
- Receptacles RNJ27: 16 cm<sup>3</sup> / h max under 2 bars pressure
- Floating RNJ26 - 46:

Front Face: 16 cm<sup>3</sup> / h max under 2 bars pressure

Rear Face: 4 cm<sup>3</sup> / h max under 0,5 bar pressure  
(higher pressure withstanding available on request)

- Salt spray:

- olive drab cadmium 500 h
- electroless nickel 48 h
- Fluid resistance:
- MIL-L-7808 (lubricating oil)
- MIL-L-23699 (lubricating oil)
- MIL-H-5606 (hydraulic fluid)
- Hydraulic fluid (Chevron M2V)
- MIL A-8243 (defrosting fluid)
- MIL- C- 87936 type I
- MIL-T-5624 (JP5)
- MIL-C-47220 or Coolanol 25 or equivalent
- MIL-G-3056 type I (gasoline)
- Isopropyl alcohol per TT-I-735 grade A or B mixed with mineral spirit TT-T-291 type I or P-D-680 type I



## MECHANICAL CHARACTERISTICS

- Insert retention in the shell: 7 bars
- Contact retention in the insert:

Contact size	22D	20	16	12	8	4	00
Maximum load (N)	45	67	110	110	150	150	150

- Mating and unmating forces

Shell size	Maximum mated force (daN)	Maximum unmated force (daN)
11	20	12
13	30	13
15	35	15
17	50	16
19	55	18
21	65	22
23	80	27
25	102	34

- Durability: 500 cycles
- Sine vibrations 10 . 2000 Hz 30g
- Random vibrations 10 . 2000 Hz 28g
- Shocks: 150g 3 ms 1/3 sinus

## ELECTRICAL CHARACTERISTICS

- Contact rating: nominal current per contact:

Contact size	22D	20	16	12	8	4	00
Current (A)	5	7.5	13	23	60	100	230

- Contact resistance:

Contact size	22D	20	16	12	8	4	00
Current resistance (mohms)	8	4.7	2	1.1	0.6	0.26	-

- Insulation resistance: - at ambient > 105 Mohms  
- at maximum temperature > 103 Mohms

- Service rating:

Service (p. 5/6)	Dielectric withstanding voltage (Vrms)								Working voltage	
	At sea level		15000 meters		21000 meters		34000 meters		Vrms	Vdc
	Mated	Unmated	Mated	Unmated	Mated	Unmated	Mated	Unmated		
M	1300	1300	800	550	800	350	800	200	400	550
I	1800	1800	1000	600	1000	400	1000	200	600	850
II	2300	2300	1000	800	1000	500	1000	200	900	1250

- Dimensions of acceptable contacts and cables:

Contact size	Contact Diameter mm (in)	Crimp barrel		Acceptable cables						
		Diameter mm (in)	Depth mm (in)	Gauge AWG				Outside diameter mm (in)		
				Section mm <sup>2</sup> (sq in)				Min	Average	Max
22D	0.76 (0.030)	0.88±0.03 (0.035±0.001)	3.58 (0.141)	22	24	26	28	0.76 (0.03)	1.20 (0.047)	1.37 (0.054)
				0.38 (0.015)	0.22 (0.009)	0.15 (0.006)				
20	1 (0.039)	1.19±0.03 (0.039±0.001)	5.30 (0.209)	20	22	24		1.02 (0.04)	1.83 (0.072)	2.11 (0.083)
				0.60 (0.024)	0.38 (0.015)	0.22 (0.009)				
16	1.57 (0.062)	1.70±0.03 (0.067±0.001)	5.30 (0.209)	16	18	20		1.68 (0.066)	2.41 (0.095)	2.77 (0.109)
				1.34 (0.053)	0.93 (0.037)	0.60 (0.024)				
12	2.36 (0.093)	2.54±0.06 (0.100±0.002)	10 (0.394)	12	14			2.46 (0.097)	3.20 (0.126)	3.61 (0.142)
				3.30 (0.013)	1.94 (0.076)					
8	3.60 (0.095)	4.6 +0.05 (0.181+0.002)-0	10 (0.394)	8 Min: 8.98 - Max: 10 (MIN: 0.354 - MAX: 0.394)				4.50 (0.177)	-	5.8 (0.228)
4	5.75 (0.226)	7.4±0.05 (0.291±0.002)	12 (0.4724)	21.10 (0.831)				7.73 (0.304)	8.08 (0.318)	8.43 (0.332)
00	12 (0.472)	14.6+0.05 (0.575±0.002)	21 (0.827)	100 (3.937)				13.3 (0.524)	-	14.7 (0.579)

**INSERT ARRANGEMENTS**

**FRONT FACE VIEW OF MALE INSERT**

The major keyway is shown in the «normal» position

Contact size	22D	20	16	12	8	4	00
Caption							

- ①: RNJ insert arrangement reference
- ②: Number of contacts
- ③: Contact sizes
- ④: Service (See page 3)

SIZE 11 SHELL

						SIZE 13 SHELL		
① 11-2	① 11-4	① 11-12	① 11-35	① 11-98	① 11-99	① 13-35	① 13-98	① 13-4
② 2	② 4	② 1	② 13	② 6	② 7	② 22	② 10	② 4
③ 20	③ 20	③ 12	③ 22D	③ 20	③ 20	③ 22D	③ 20	③ 16
④ I	④ I	④ II	④ M	④ I	④ I	④ M	④ I	④ I

SIZE 13 SHELL		SIZE 15 SHELL			
① 13-26	① 15-5	① 15-19	① 15-35	① 15-97	
② 6+2	② 5	② 19	② 37	② 4+8	
③ 22D 12	③ 16	③ 20	③ 22D	③ 16 20	
④ M	④ II	④ I	④ M	④ I	

SIZE 17 SHELL

① 17-6	① 17-8	① 17-26	① 17-35	① 17-75	① 17-99
② 6	② 8	② 26	② 55	② 2	② 2+21
③ 12	③ 16	③ 20	③ 22 D	③ 8 TWINAX	③ 16 20
④ I	④ II	④ I	④ M	④ I	④ I

SIZE 19 SHELL

① 19-11	① 19-32	① 19-35
② 11	② 32	② 66
③ 16	③ 20	③ 22 D
④ II	④ I	④ M

SIZE 21 SHELL

① 21-11	① 21-16	① 21-35	① 21-39	① 21-41	① 21-48	① 21-75
② 11	② 16	② 79	② 2+37	② I	② 4	② 4
③ 12	③ 16	③ 22D	③ 16 20	③ 41	③ 8 Puissance	③ 8 Coax
④ 1	④ 11	④ M	④ I	④ 20	④ M	④ I

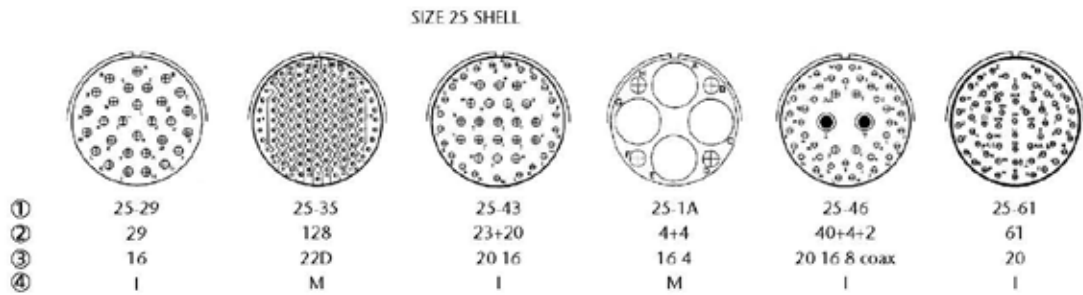
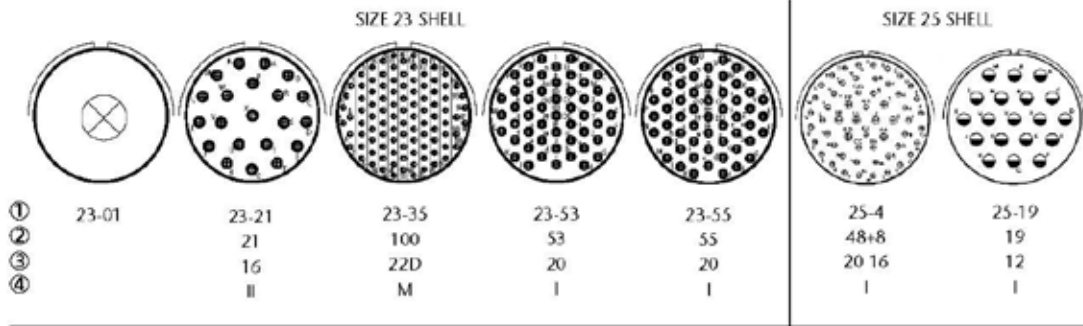

Insert arrangements	Service (see page 4)	Number of contacts	Number of contacts by size							
			22D	20	16 Power	12 Power Coax	8 Coax Triaxial	8 Power	4 Power	00 Power
11-2	I	2		2						
11-4	I	4		4						
11-12	II	1				1				
11-35	M	13	13							
11-98	I	6		6						
11-99	I	7		7						
13-4	I	4			4					
13-26	M	8	6			2				
13-35	M	22	22							
13-98	I	10		10						
15-5	II	5			5					
15-19	I	19		19						
15-35	M	37	37							
15-97	I	12		8	4					
17-6	I	6				6				
17-8	II	8			8					
17-26	I	26		26						
17-35	M	55	55							
17-75	I	2				2				
17-99	I	23		21	2					
19-11	II	11			11					
19-32	I	32		32						
19-35	M	66	66							
21-11	I	11				11				
21-16	II	16			16					
21-35	M	79	79							
21-39	I	39		37	2					
21-41	I	41		41						
21-48	I	4					4			
21-75	I	4					4			
23-01		1								1
23-21	II	21			21					
23-35	M	100	100							
23-53	I	53		53						
23-55	I	55		55						
25-4	I	56		48	8					
25-19	I	19				19				
25-29	I	29			29					
25-35	M	128	128							
25-43	I	43		23	20					
25-1A	M	8			4			4		
25-46	I	46		40	4		2			
25-61	I	61		61						

Please consult us for other insert arrangements.

OVERALL DIMENSIONS

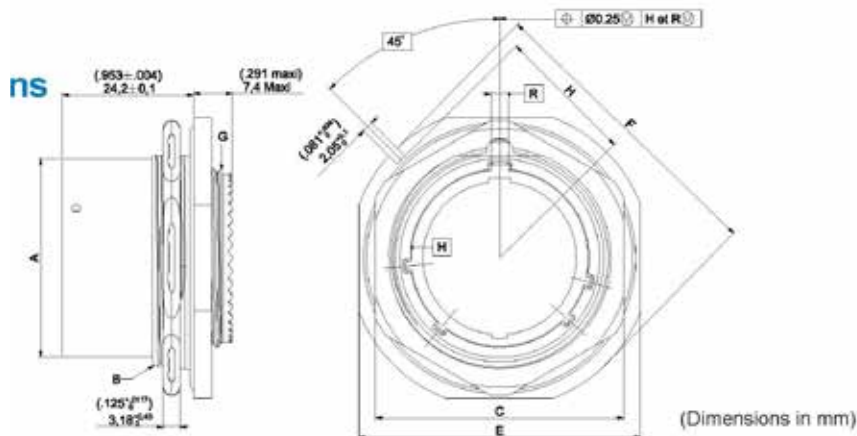

RECEPTACLE

Jam nut receptacle for both crimp and PCB contacts

Shell size	Diameter A Max.	Thread B UNEFC Class 2A	C Max.	E +0.48 0 (+.019) 0	Diameter F +0.41 0 (+.016) 0	Thread G UNEFC Class 2A	H0 -0.2 0 (-.008)	Mass with contacts (average)	
	mm (inch)							mm (inch)	mm (inch)
11	17.81 (.701)	.8125-20	25.80 (1.016)	31.49 (1.240)	34.93 (1.375)	.5625-24	15.33 (.604)	16	19.5
13	21.62 (.851)	1.000-20	30.00 (1.181)	34.69 (1.366)	38.10 (1.500)	.6875-24	16.92 (.666)	22.5	28
15	24.80 (.976)	1.125-18	33.00 (1.300)	37.79 (1.488)	41.28 (1.625)	.8125-20	18.51 (.729)	28	37
17	27.97 (1.101)	1.250-18	37.00 (1.457)	40.99 (1.614)	44.45 (1.750)	.9375-20	20.10 (.791)	33	46.5
19	30.69 (1.208)	1.375-18	40.00 (1.575)	45.79 (1.803)	49.23 (1.938)	1.0625-18	22.67 (.893)	41.5	58.5
21	33.86 (1.333)	1.500-18	43.00 (1.693)	48.99 (1.929)	52.37 (2.062)	1.1875-18	24.26 (.955)	50.5	71
23	37.04 (1.458)	1.625-18	46.00 (1.811)	52.09 (2.051)	55.58 (2.188)	1.3125-18	25.84 (1.017)	55.50	82.5
25	40.22 (1.583)	1.750-18	51.20 (2.016)	55.29 (2.177)	58.72 (2.312)	1.4375-18	27.43 (1.080)	63	98

Plug

With rear accessory possibility

Without rear accessory possibility

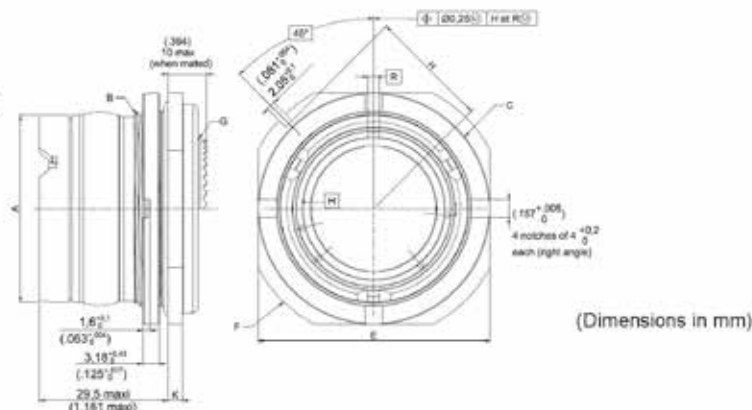

PLUG

With rear accessory possibility

Shell size	Diameter A +0.03 -0.1 (+.001) -.004	Thread B UNEFC Class 2A	C Max.	E0 -0.25 0 (-.01)	Diameter F ±0.41 (±.016)	Thread G UNEFC Class 2A	H0 -0.25 0 (-.01)	K +0.28 -0.25 (+.011) -.01	Mass with contacts (average)	
	mm (inch)								mm (inch)	mm (inch)
11	23.00 (.906)	1.000-20	32.23 (1.264)	32.16 (1.266)	38.10 (1.500)	.5625-24	16.92 (.666)	2.77 (.109)	24	28
13	26.80 (1.055)	1.125-18	35.25 (1.388)	35.34 (1.391)	41.28 (1.625)	.6875-24	18.51 (.729)	2.77 (.109)	28	34
15	30.00 (1.181)	1.250-18	38.40 (1.512)	38.51 (1.516)	44.45 (1.750)	.8125-20	20.10 (.791)	2.77 (.109)	32	41
17	33.22 (1.308)	1.375-18	41.60 (1.638)	41.69 (1.641)	49.23 (1.938)	.9375-20	22.67 (.893)	2.77 (.109)	38	51
19	36.20 (1.425)	1.500-18	46.30 (1.823)	46.43 (1.828)	52.37 (2.062)	1.0625-18	24.26 (.955)	3.56 (.14)	48	65
21	39.40 (1.551)	1.625-18	49.60 (1.953)	49.64 (1.954)	55.58 (2.188)	1.1875-18	25.84 (1.017)	3.56 (.14)	67	87
23	42.60 (1.677)	1.750-18	52.70 (2.075)	52.78 (2.078)	58.72 (2.312)	1.3125-18	27.43 (1.080)	3.56 (.14)	83	111
25	45.68 (1.798)	1.875-16	53.93 (2.213)	54.03 (2.128)	59.10 (2.327)	1.4375-18	27.58 (1.086)	3.56 (.14)	104	125

Only RNJ specific dimensions are mentioned in these figures. -All dimensions which are not mentioned meet the MIL-DTL-38999 Series I Standard.

## CONNECTOR MOUNTING

### Generalities

- The dimension of  $36^{+0}_{-0.5}$  between the flanges is mandatory to secure the technical performances at the mating position.
- A guiding system has to ensure the correct positioning of the rack independently of the connectors.
- No mechanical stress must be applied to the rear of the plug by the wires.
- To mount an accessory on the plug, it is necessary to use a holding support to avoid strain on the internal set of the plug.
- A stainless steel pin is delivered with both plug and receptacle connectors. The pin ensures a perfect positioning of the connector on the panel.

### Mated connectors

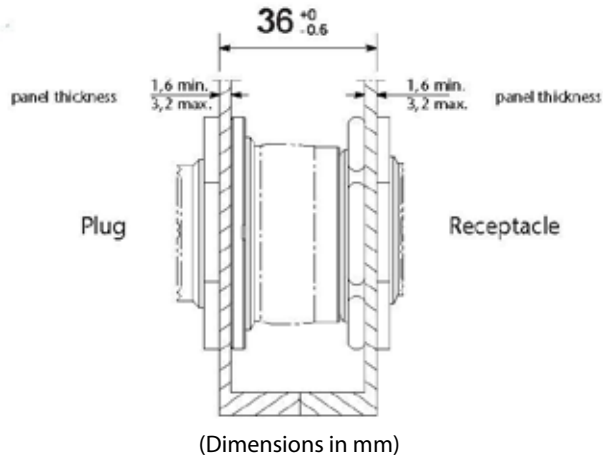

## PANEL DRILLING AND RECOMMENDED NUT COUPLING TORQUE

Shell size		K min	W	Diam. X +0.1/-0	Nut coupling torque	Clamping bush for RNJ plug
Plug	Receptacle	mm (in)	mm (in)	mm (in)	N.m	
-	11	-	11.69 (0.460)	20.88 (0.822)	4.5/5.7	-
11	13	32.60 (1.283)	12.81 (0.504)	25.58 (1.007)	6.2/6.8	RNJ 8982 A11
13	15	36.00 (1.417)	13.94 (0.549)	28.80 (1.134)	7.9/8.5	RNJ 8982 B13
15	17	39.60	15.06 (1.559)	31.98 (0.593)	9.0/9.6 (1.259)	RN J8982 C15
17	19	43.30 (1.705)	16.88 (0.665)	35.15 (1.384)	10.2/10.7	RNJ 8982 D17
19	21	47.00 (1.850)	18.00 (0.709)	38.28 (1.507)	11.3/12.4	RNJ 8982 E19
21	23	50.60 (1.992)	19.12 (0.753)	41.50 (1.634)	12.4/13.6	RNJ 8982 F21
23	25	54.20 (2.134)	20.24 (0.797)	44.68 (1.759)	13.6/14.7	RNJ 8982 G23
25	-	59.70 (2.350)	20.30 (0.799)	48.08 (1.893)	15.8/16.9	RNJ 8982 H25

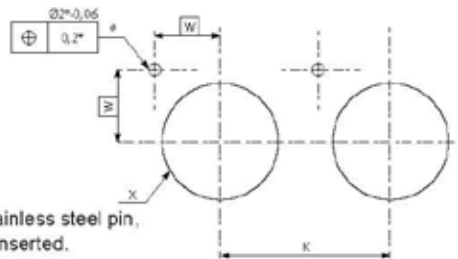

## REAR ACCESSORIES COUPLING TORQUE

The following values must be respected. Before applying this coupling torque, locking glue has to be put on the rear thread of the connector.

Shell size	11	13	15	17	19	21	23	25
Coupling torque (Nm)	8 ± 0.4	11 ± 0.5	11 ± 0.5	14 ± 0.7	14 ± 0.7	17 ± 0.8	17 ± 0.8	20 ± 1

### STANDARD PCB TAIL DIMENSIONS FOR RNJ 27 CI RECEPTACLES

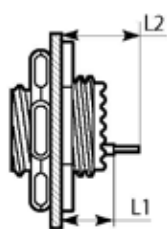

		RNJ 27 CI	
		mm (in)	
P	L1	min 7.89 (0.311)	
		max 8.57 (0.337)	
S	L2	min 12.79 (0.504)	
		max 13.67 (0.538)	
P	L1	min 7.69 (0.302)	
		max 8.37 (0.330)	
S	L2	min 12.59 (0.496)	
		max 13.47 (0.530)	



(Other dimensions available upon request)

For specific RNJ 46 plugs equipped with PCB contacts (flex circuit applications), please consult us.

New: RNJ receptacles for PCB applications

Now available with stand off with holes for M3 screws for fixation on the board.

### HOW TO ORDER

Series	RNJ	26	T	11	35	P	N	014	LC	-
Shell type	26: Plug with accessory possibility 27: Jam nut receptacle 46: Plug without accessory possibility (For plug and receptacle with square flange, please consult us)									
Service class and contact type	T: Environmental crimp applications, # 22D/20/16/12/8/4/00 CI: Environmental solder applications on PCB (receptacle only), # 22D/20/16 (for sizes 12 and 8, please consult us) DW: Environmental wire-wrapping applications (receptacle only), # 22D/20									
Shell size	11/13/15/17/19/21/23/25									
Insert arrangement	See pages 4/5									
Contact style	P: Pin S: Socket									
Polarization	N: Normal position only (Letter N is required)									
Shell finish	014: Olive drab cadmium 023: electroless nickel									
Contacts	Blank: Connector delivered with contacts LC: Connector delivered without contact ("LC" not marked on the connector)									
Deviation	F404: Tinned PCB contacts For other deviations (FXXX), please consult us									

### CLAMPING BUSH FOR RNJ PLUG



For # 11: RNJ8982A11  
For # 13: RNJ8982B13  
For # 15: RNJ8982C15  
For # 17: RNJ8982D17

For # 19: RNJ8982E19  
For # 21: RNJ8982F21  
For # 23: RNJ8982G23  
For # 25: RNJ8982H25

# ABOUT AMPHENOL

Founded in 1932, **Amphenol** is one of the largest manufacturers of interconnect products in the world. The company designs, manufactures, and markets electrical, electronic, and fiber optic connectors, interconnect systems, and coaxial and specialty cables.

**Amphenol** has a diversified presence as a leader in high growth areas of the interconnect industry and provides solutions for customers in the automotive, broadband, industrial, information technology and data communications, military and aerospace, mobile devices, and mobile networks markets.

More info on [www.amphenol.com](http://www.amphenol.com)

**Amphenol**  
ENABLING THE ELECTRONICS REVOLUTION

## Europe

FRANCE	Amphenol AIR LB	2 rue Clément Ader, ZAC de Wé - 08110 Carignan	+33 3 24 22 78 49
FRANCE	Amphenol SEFEE	Z.I. des Cazes – BP243 - 12402 Saint-Affrique Cedex	+33 5 65 98 11 00
GERMANY	Amphenol AIR LB GMBH	Am Kleinbahnhof 4 - 66740 Saarlouis	+49 6831 981 00
ITALY	Amphenol EUROPEAN SALES OPERATIONS	Via Barbaiana n.5 - 20020 Lainate - Milano	+39 293 254 214
UNITED KINGDOM	Amphenol INVOTEC	Unit 1-3, Hedging Lane Industrial Estate, Dosthill - Tamworth, B77 5HH	+44 1827 263 000
UNITED KINGDOM	Amphenol IONIX SYSTEMS	Prospect House, Taylor Business Park, Risley, Warrington, WA3 6HP	+44 1 942 685 200
UNITED KINGDOM	Amphenol LTD	Thanet Way, Whitstable - KENT, CT53JF	+44 1227 773 200
UNITED KINGDOM	Amphenol MARTEC	St Augustines Business Park, Swalecliffe Whitstable - Kent CT5 2QJ	+44 1227 793 733

## North America

CANADA	Amphenol CANADA	605 Milner avenue - Toronto, Ontario	+1 416 291 0647
USA	Amphenol AEROSPACE OPERATIONS	40-60 Delaware street - Sidney, NY 13838	+1 800 678 0141
USA	Amphenol BORISH TECHNOLOGIES	4511 East Paris AVE - Grand Rapids, MI 49512	+1 616 554 9820
USA	Amphenol FSI	1300 Central Expwy N, Suite 100 - Allen, TX 75013	+1 214 547 2400
USA	Amphenol GRIFFITH ENTERPRISES	6000 East Coury Drive - Cottonwood, AZ 86326	+1 928 634 3685
USA	Amphenol NEXUS TECHNOLOGIES	50 Sunnyside Avenue - Stamford, CT 06902	+1 203 327 7300
USA	Amphenol PCD	72 Cherry Hill Drive - Beverly, MA. 01915	+1 978 624 3400
USA	Amphenol PRINTED CIRCUIT	Board Technology, 91 Northeastern Boulevard - Nashua, NH 03062	+1 603 324 4500
USA	Amphenol SV MICROWAVE	2400 Centrepark West Drive - West Palm Beach, FL	+1 561 840 1800
USA	Amphenol TIMES MICROWAVE	358 Hall Avenue - Wallingford, CT 06492	+1 800 867 2629

## Asia

CHINA	Amphenol PCD CO.	Building 21, 1 <sup>st</sup> Liao Keng Industrial Zone, Shi Yan Street - Bao An District - Shenzhen 518108	+86 755 8173 8000/8286
INDIA	Amphenol INTERCONNECT INDIA	105 Bhosari Industrial Area - Pune 411 026	+91 20 27120363
JAPAN	Amphenol JAPAN	471-1, Deba, Ritto-City - Shiga 520 3041	+81 77 553 8501
KOREA	Amphenol DAESHIN	558 SongNae-Dong SoSa-Gu, Bucheon-city, Kyunggi-Do - 420-130	+81 32 610 3830/3845
SINGAPORE	Amphenol EAST ASIA	26/F, Railway Plaza, 39 Chatham Road South, Tsim Sha Tsui, Kowloon, Hong Kong	+65 6294 2128

## Other Areas

AFRICA	Amphenol AFRICA	30 Impala Rd - Sandton 2146	+27 82 410 5179
ARGENTINA	Amphenol ARGENTINA	Av. Callao 930 2do piso Oficina B "Plaza" C1023 - AAP Buenos Aires	+54 11 4815 6886
AUSTRALIA	Amphenol AUSTRALIA PTY	2 Fiveways Blvd., Keysborough - Melbourne - Victoria 3173	+61 3 8796 8888
BRAZIL	Amphenol DO BRAZIL	Rua Diogo Moreira, 132, 20 andar, rooms 2001-2-3	+55 11 3815 1003
ISRAEL	Amphenol BAR-TEC	3 Hagavish Street, K fir-Barkan Bldg. East Industrial Zone - Kfar-Sava, 44102	+972 9 764 4100
MEXICO	Amphenol OPTIMIZE	Carretera Internacional Km 6.5, Col. Parque Industrial, Nogales, Sonora, C.P. 84094	+52 631 311 160
NEW ZEALAND	Amphenol PHITEK	Level 4, 2 Kingdon Street, Newmarket, Auckland 1023	+64 9 524 2984
TURKEY	Amphenol TURKEY	Sun Plaza 15 Kat: 15 Masiak Hah. Bilim Sok. No.5 - Sisli/Istanbul, 34398	+90 212 367 92 19

# Amphenol SOCAPEX



## Amphenol Socapex

948, promenade de l'Arve BP29  
74311 Thyez Cedex - France  
Phone: +33 (0)4 50 89 28 00  
[contact@amphenol-socapex.fr](mailto:contact@amphenol-socapex.fr)  
[www.amphenol-socapex.com](http://www.amphenol-socapex.com)



## For Technical Support

+33 (0)4 50 89 28 49  
[technicalsupport@amphenol-socapex.fr](mailto:technicalsupport@amphenol-socapex.fr)  
[www.amphenol-socapex.com/technical\\_support](http://www.amphenol-socapex.com/technical_support)



## To buy our products

+33 (0)4 50 90 28 00  
[contact@amphenol-socapex.fr](mailto:contact@amphenol-socapex.fr)  
[www.amphenol-socapex.com/amphenol/sales](http://www.amphenol-socapex.com/amphenol/sales)  
Request a quote online at [www.amphenol-socapex.com/quotation\\_request](http://www.amphenol-socapex.com/quotation_request)





## Documentation

[www.amphenol-socapex.com/documentation](http://www.amphenol-socapex.com/documentation)  
To order a paper version of our catalogs, send an e-mail to [communication@amphenol-socapex.fr](mailto:communication@amphenol-socapex.fr)



[www.amphenol-socapex.com](http://www.amphenol-socapex.com)

Follow Amphenol Socapex on social media :    

This catalog uses paper from managed forests, PEFC & FSC labels, and is printed by a printer certified "Imprim'Vert®"

We reserve the right to modify our products in any way we deem necessary.  
Any duplication is prohibited, unless approved in writing.

Designed by Amphenol Socapex  
DOC-000019-ANG - January 2025