

AirBorn
a **molex** company

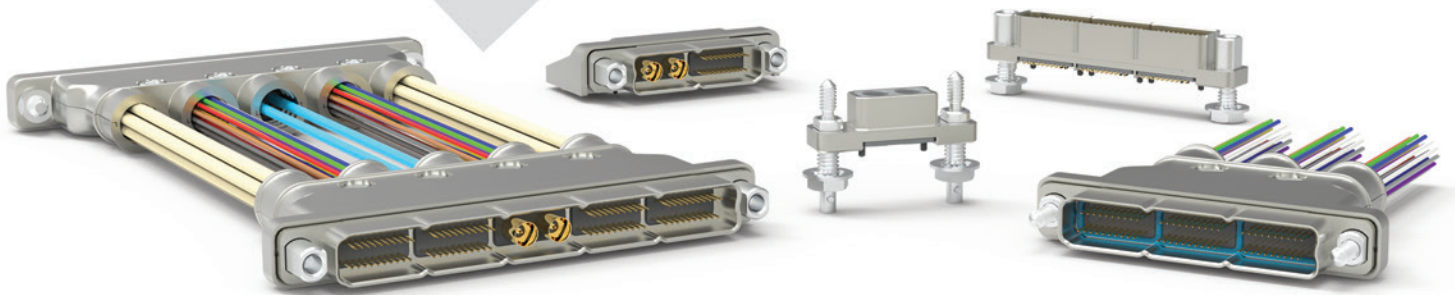

SINERGY[®]

Ultra High-Density Modular Interconnects

Complete Electronic Solutions



AirBorn is an employee owned company whose core business is engineering & manufacturing specialized connectors & electronic components for OEMs worldwide. We serve customers across many industries including: Commercial Air, Industrial, Medical, Military/Defense, & Space Exploration.

Companies today are looking for more than a supplier, they're looking for a strategic partner to collaborate & grow with. AirBorn products are trusted to perform in extreme conditions, where mission-critical reliability is vital to success. Customers trust AirBorn products, and have for over 60 years.

AirBorn Engineering = Problem Solved®

AirBorn's engineering group specializes in new product design and development for OEMs across the globe. Our team of 50+ degreed engineers are the most innovative and committed to solving our customer's challenges, but that's only the beginning of where we can help! Leverage our design and manufacturing expertise throughout the entire product development process. From conceptual design, prototyping, pilot-runs through to mass production, our teams work efficiently to cut down your program's time to market.

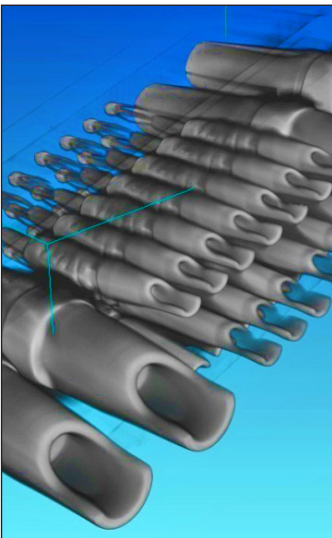

Solution Engineering

AirBorn has a dedicated team of experienced and degreed solution engineers on staff to help solve your most pressing electronic challenges.

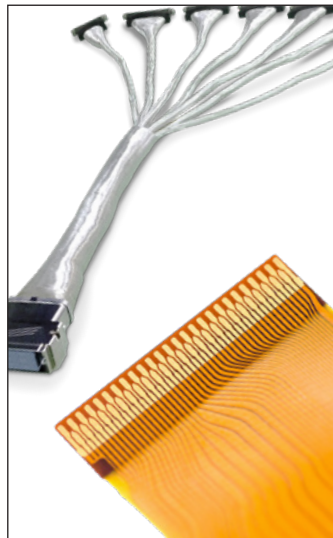

Cable vs. Flex Assemblies

We manufacture cable and flex assemblies and can impartially recommend whichever solution is best for your distinct design or application.



Signal Integrity Expertise

Whether a new design retrofit, or a field issue, let us help you design an end-to-end interconnect solution to support your high-speed signal integrity design.

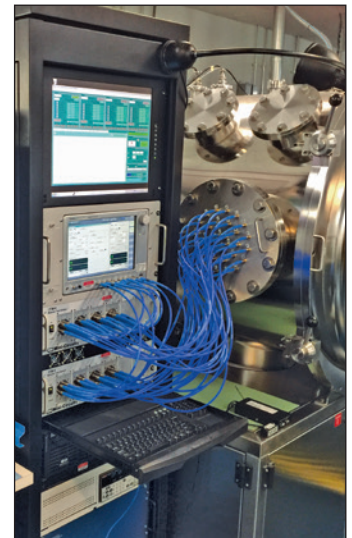

Lab & Test Services

We'll test against the highest standards imaginable to ensure your products stand up to the rigors of space, military, commercial air, and industrial applications.

Connectors



Micro D
M Series



High-Speed Micro D
microSI



Nano D
N Series



High-Speed Modular
Slnergy

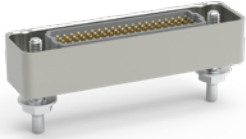

Rectangular 25Gbps
verSI

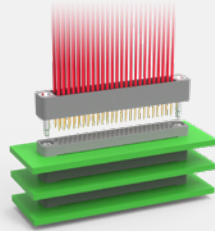

Stackable
RC Series

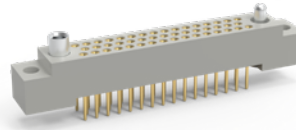

Rectangular
R Series

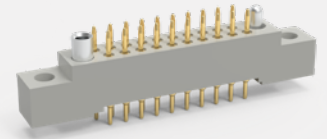

Rectangular
W Series

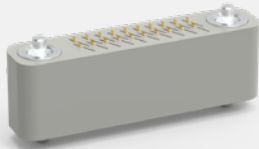

Z Axis Interposer
Z Series

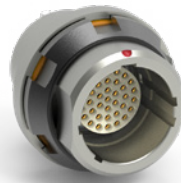

Circular
Series 360



Strip Connector
AirStrip



Macro D
RockEt

Assemblies

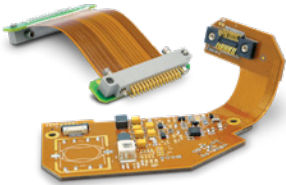

Flexible Circuit Assemblies



Cable Assemblies



FUZE Assemblies



Active Optical Assemblies

Embedded Systems



Rugged Power Systems

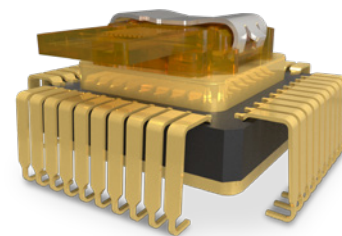

Photonics/Optoelectronics

AirBorn In Action



Voyager Program

AirBorn Solutions Are "In-Action" Inside Many Important & Famous Applications

AirBorn Inc. was founded in 1958 to manufacture electronic connectors for aviation applications — a name that reflects our heritage. By 1960, our 12 employees had engaged with customers such as Motorola Inc., Texas Instruments (now Raytheon), Lockheed Aircraft, Boeing, and Burroughs. Since our founding, we have participated in many significant projects in human history. The Voyager I and II program, launched in 1977 and still traversing interstellar space today, exemplifies how customers view AirBorn parts: rugged, reliable, and long-lasting.

We're proud to contribute to the expansive defense and security efforts of America and its allies. Our components have been integrated into a wide range of advanced aviation, ground, and naval systems, as well as key elements in cutting-edge missile programs. We excel at delivering exceptional quality for mission-critical applications.

Although aerospace, defense, and space applications are our specialties, we do not stop there. AirBorn parts are integral components of commercial aircraft, MRI machines, defibrillators, and pain management systems. From the depths of the sea to the far reaches of space, our connectors are engineered to overcome any challenge.



Mars Rovers



Commercial Airliners



Military Communications & Rifle Scopes



Pain Management Systems



International Space Station

Slnergy® Overview

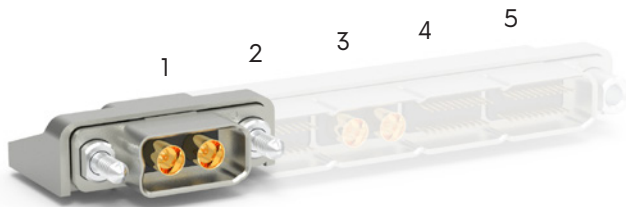

Multi-bay, die-cast metal connector system with interchangeable molded insulator bays.

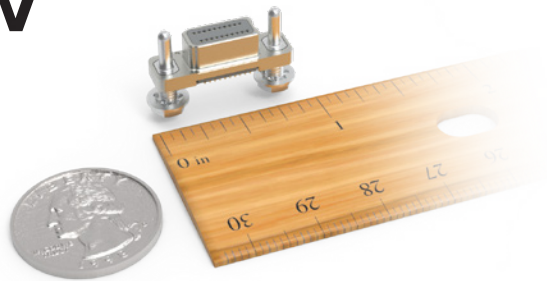

1 and 2 bay Slnergys are roughly the size of a U.S. quarter — similar to Micro & Nano Ds.



SMPM RF interface (.173"/4.39mm) available in cable & board-mount models.



Vertical & right-angle board-mount connectors. Discrete Wire, SMPM RF, & Twinax cabling assemblies.

Small & Modular with Speeds up to 25Gbps!

Introducing AirBorn's Slnergy family of connectors! Slnergy offers OEMs a mini-modular hybrid solution in 1-5 configurable bays. With speeds up to 25Gbps per lane or 75Gbps aggregate bidi bandwidth, Slnergy meets requirements for XAUI, USB 3.0, PCIe Gen 3/4, SAS-3/4, and Ethernet (10G/25G per lane) applications. Exemplifying mil-grade resilience, this high-speed, high-density connector is tested & qualified to MIL-DTL-83513 performance requirements.

Ideal for Mil-Aero, Space, & Industrial applications, Slnergy's 4 points-of-contact will handle a very rough ride. Configure your Slnergy with interchangeable locking, jacking, or guide hardware with SMT signal termination. Customers have relied on AirBorn's quality and innovation since our inception in 1958.

Key Features & Benefits:

- .0315" (.8mm) signal & .173" (4.39mm) SMPM RF pitch
- 4 points-of-contact
- Discrete wire, SMPM RF, & Twinax cable variations
- High-density, multi-bay system
- Interchangeable molded signal & SMPM RF insulator bays
- IPC-A-610 Class 3 SMT termination
- Locking, jacking, & guide hardware
- Rugged die-cast or machined metal bodies
- Speeds up to 25Gbps per lane
- Qualification test based on MIL-DTL-83513 performance requirements

Excellent Design Flexibility

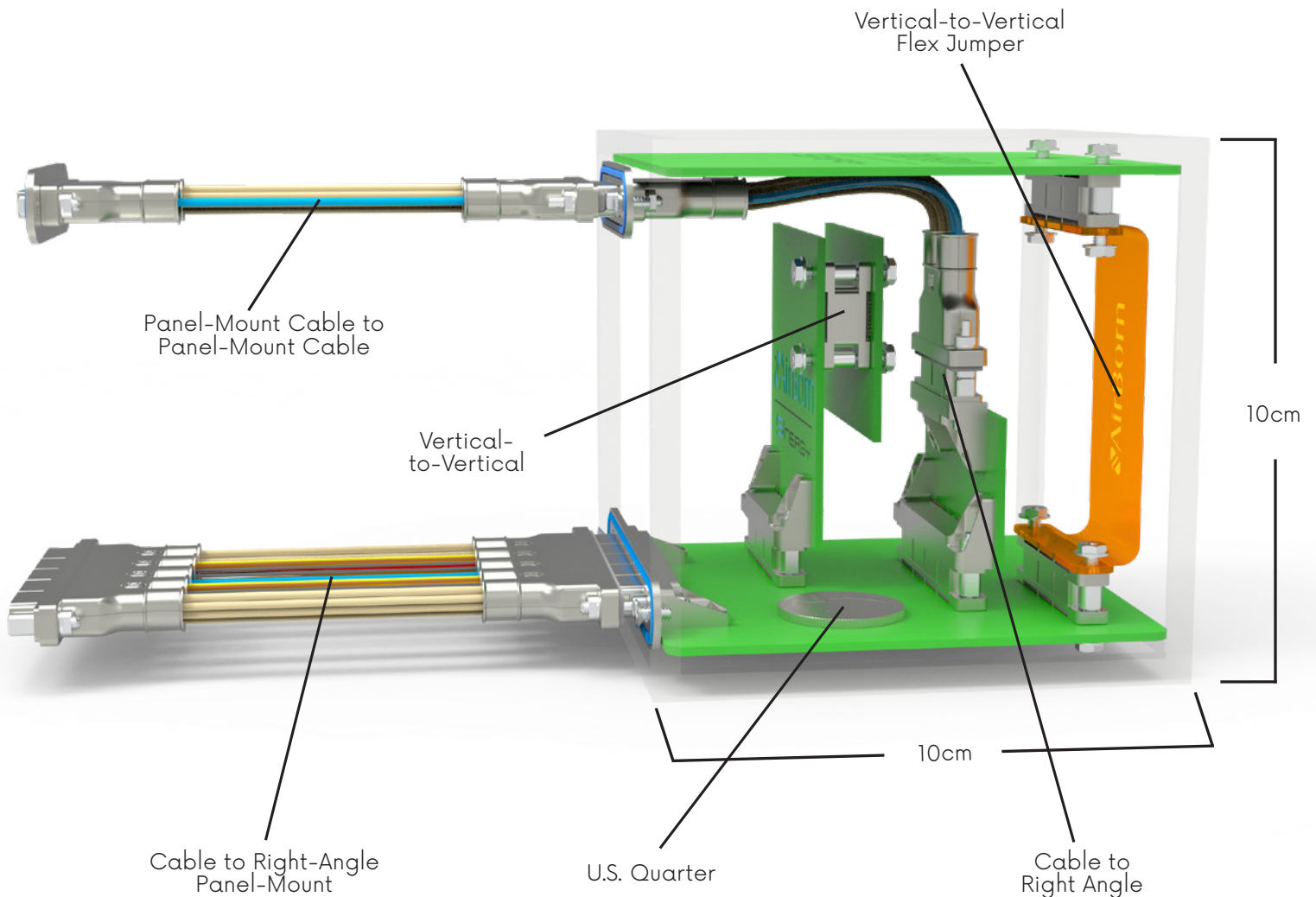

SInergy's Modularity & Versatility

SInergy is a high-speed, high-density configurable solution. OEMs and design engineers can mix and match any available module within a single interface. SInergy offers vertical board-mount, right-angle board-mount, cable I/O, and flex circuit mounting options to navigate box design challenges.

Take advantage of SInergy's small form factor and flexible circuits to navigate any box design challenges. SInergy is a great solution to challenging design geometries, even in the toughest mil-aero, space, and industrial applications where mission-critical reliability is paramount.

Critical to Success Applications

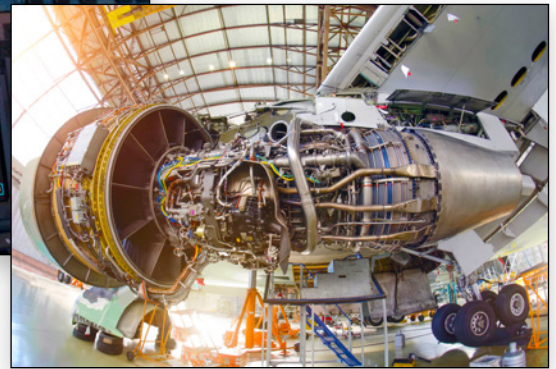

Ruggedness & Reliability: Keys to Surviving the Harshest Applications

When it comes to durability in intense environments, AirBorn's new SInergy connectors are a rugged and reliable solution in a small package. From a high-vibration rocket launch to the temperature fluctuations of a jet fighter or commercial airliner, SInergy connectors are designed to withstand all of that and much more.

Looking for a rugged and reliable connector that's endured the harshest environments of Earth and space, look no further than AirBorn's SInergy connectors. Count on the quality and engineering ingenuity AirBorn's offered customers since 1958.

Applications

- Avionics
- Cube Satellites
- FADEC System
- Head-Up Displays
- Industrial Equipment
- Military Drones
- Missile Systems
- Radar Systems
- Radio Communications
- RF Antenna Applications

SInergy[®] Is Designed Into:



Avionics



Radio Communications



Satellites

And More...



Drones



Missile Systems

Dimensions

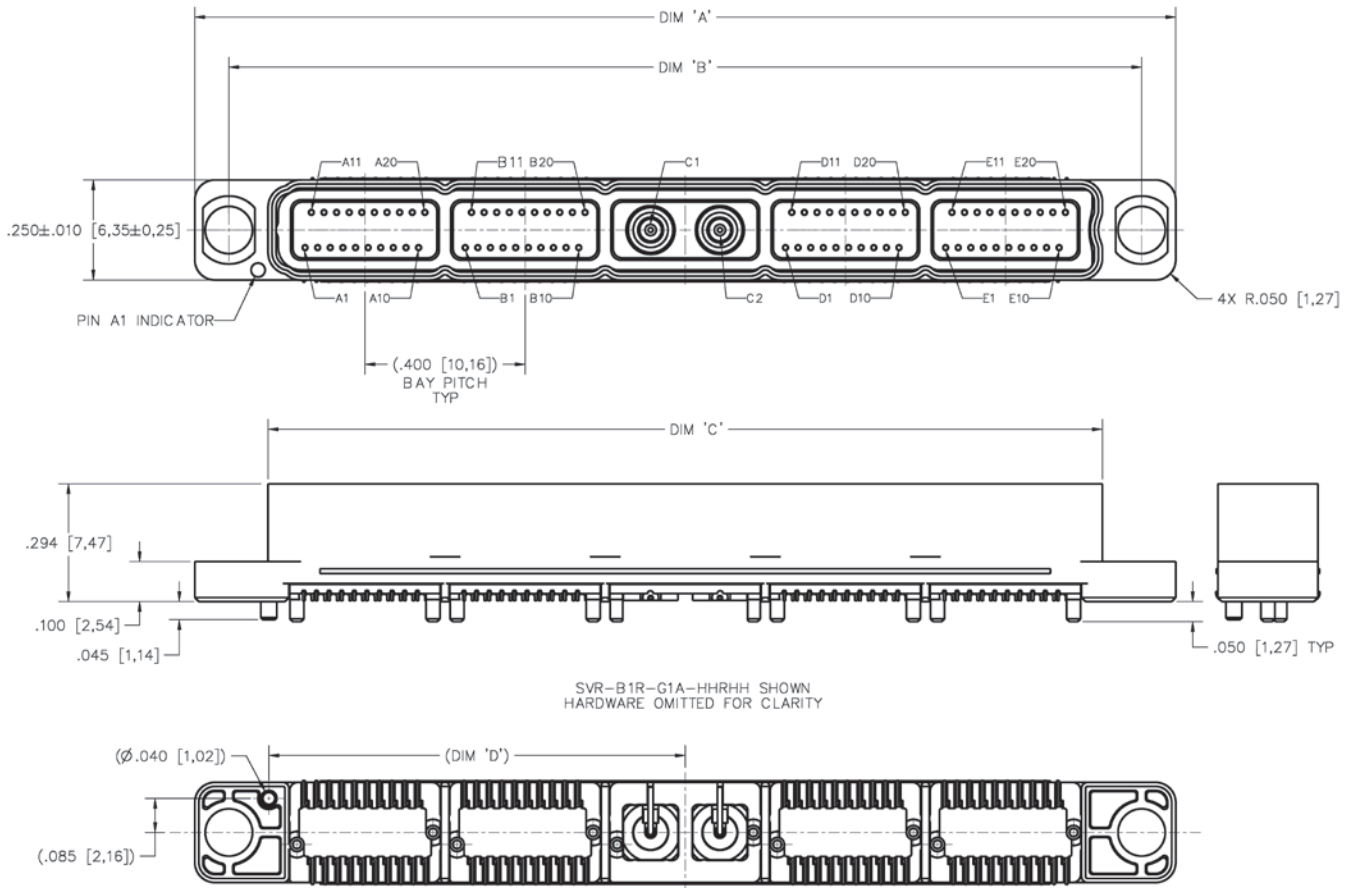

NUMBER OF BAYS	DIM 'A'	DIM 'B'	DIM 'C'	DIM 'D'
1 BAY	.850 [21,59]	.680 [17,27]	.484 [12,29]	.240 [6,10]
2 BAYS	1.250 [31,75]	1.080 [27,43]	.884 [22,45]	.440 [11,18]
3 BAYS	1.650 [41,91]	1.480 [37,59]	1.284 [32,61]	.640 [16,26]
4 BAYS	2.050 [52,07]	1.880 [47,75]	1.684 [42,77]	.840 [21,34]
5 BAYS	2.450 [62,23]	2.280 [57,91]	2.084 [52,93]	1.040 [26,42]

Please consult the AirBorn website for the latest revision of this document prior to beginning any design work.

SVR Panel Mounting Instructions

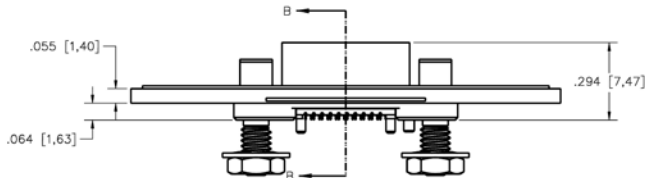
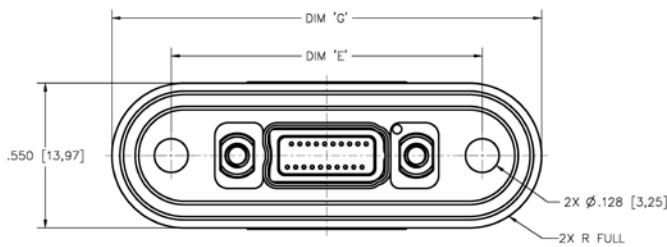
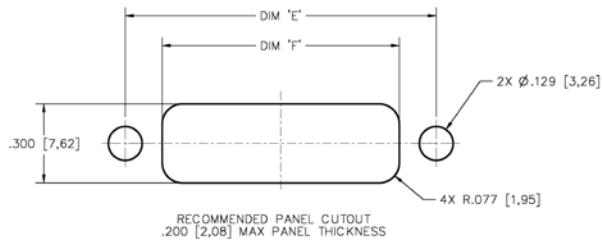

NUMBER OF BAYS	DIM 'E'	DIM 'F'	DIM 'G'
1 BAY	1.180 [29,97]	900 [22,86]	1.630 [41,40]
2 BAYS	1.580 [40,13]	1.300 [33,02]	2.030 [51,56]
3 BAYS	1.980 [50,29]	1.700 [43,18]	2.430 [61,72]
4 BAYS	2.380 [60,45]	2.100 [53,34]	2.830 [71,88]
5 BAYS	2.780 [70,61]	2.500 [63,50]	3.230 [82,04]

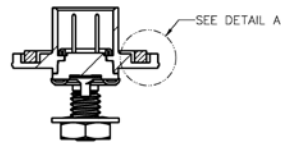
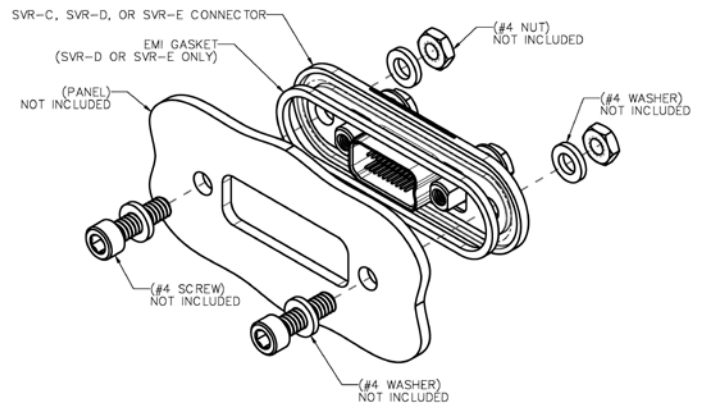

SECTION B-B

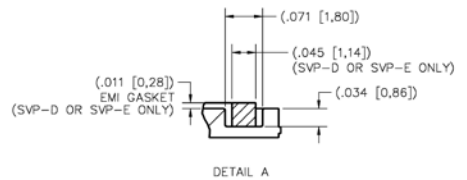

DETAIL A

Please consult the AirBorn website for the latest revision of this document prior to beginning any design work.

All Modules		
Molded Insulators	Material	Glass-filled liquid crystal polymer (LCP)
Shells	Material	Zinc alloy 3 per SAE AMS4803 (AG40A) or aluminum alloy 6061-T6 per SAE AMS-4027 or 6061-T6511 per SAE AMS-QQ-A-200/8
	Finish	Electroless nickel, 500µ in min per SAE AMS2404, class 3
Hardware	Washer Material	Stainless steel per SAE NASM35333 (ASTM A240)
	Washer Finish	Passivated per SAE NASM35333 (SAE AMS-2700)
	Jack Post Material	Nitronic 60 per ASTM A193/A193M
	Jack Post Finish	Passivated per SAE AMS-2700
	Remaining Hardware Material	Stainless steel per ASTM A484/A484M, ASTM A582/A582M, or ASTM A320
	Remaining Hardware Finish	Passivated per SAE AMS-2700
Interfacial Seal	Material	Fluorosilicone elastomer per MIL-DTL-25988
Panel-Mount Gasket	Material	Conductive elastomer per MIL-DTL-83528, type D
HD Modules		
Pin Contact	Material	Phos bronze per ASTM B103
	Finish (Pin End)	50µ in min localized gold per ASTM B 488, type II, code C over 50µ in min nickel per ASTM B689, type 1
	Finish (Termination)	10-20µ in localized gold flash per ASTM B488 type I, code A or C over 50µ in min nickel per ASTM B689 type 1
Embedment	Material	Frey Eng. Co. Insulating compound CF3003-80 or equivalent
RF Modules		
RF Contact	Material (Pin & Socket)	BeCu per ASTM B196
	Material (Bushings)	Brass per JIS-C3604
	Material (Dielectric)	PTFE (white) per ASTM D1710
	Finish (Pin & Socket)	30µ in min localized gold over 100µ in min nickel per MIL-G-45204 type 1, class 4
	Finish (Bushing & Center Termination)	10µ in min localized gold over 100µ in min nickel per MIL-G-45204 type 1, class 2
	Finish (Dielectric)	N/A

Please consult the AirBorn website for the latest revision of this document prior to beginning any design work.

Dimensions

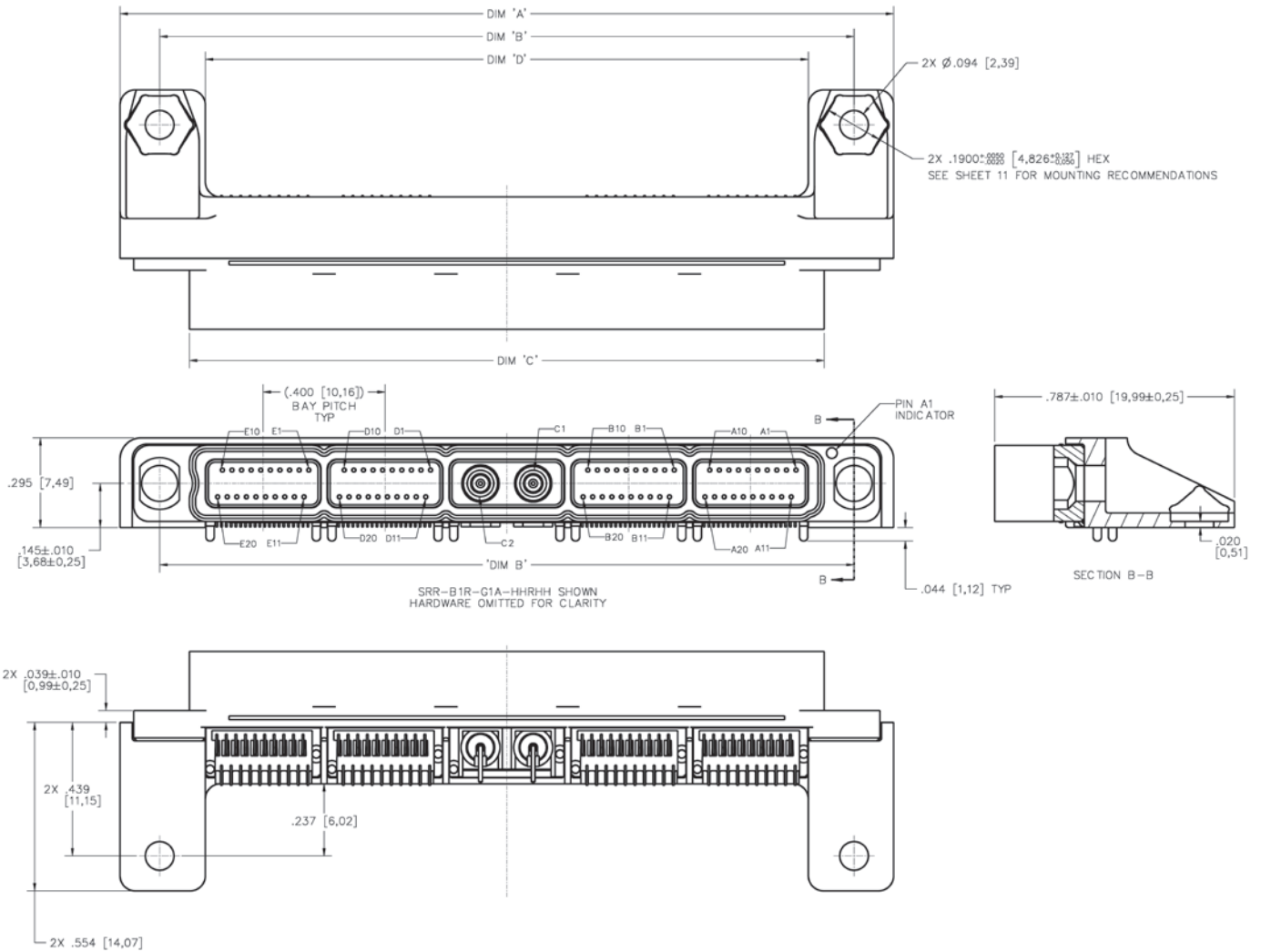

NUMBER OF BAYS	DIM 'A'	DIM 'B'	DIM 'C'	DIM 'D'
1 BAY	940 [23,88]	680 [17,27]	484 [12,29]	.380 [9,65]
2 BAYS	1,340 [34,04]	1,080 [27,43]	884 [22,45]	.780 [19,81]
3 BAYS	1,740 [44,20]	1,480 [37,59]	1,284 [32,61]	1,180 [29,97]
4 BAYS	2,140 [54,36]	1,880 [47,75]	1,684 [42,77]	1,580 [40,15]
5 BAYS	2,540 [64,52]	2,280 [57,91]	2,084 [52,93]	1,980 [50,29]

Please consult the AirBorn website for the latest revision of this document prior to beginning any design work.

SRR Panel Mounting Instructions

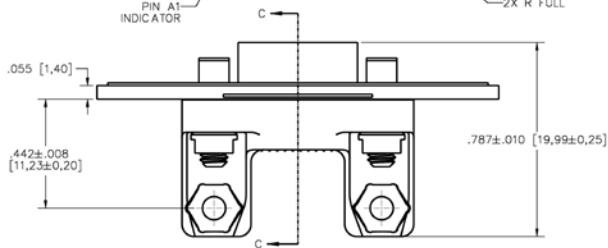
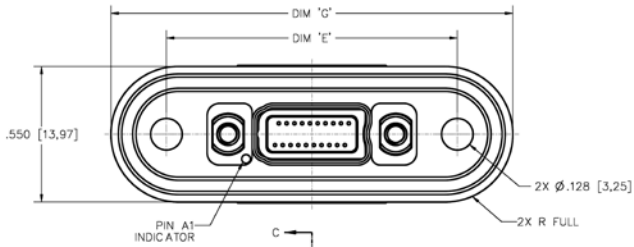
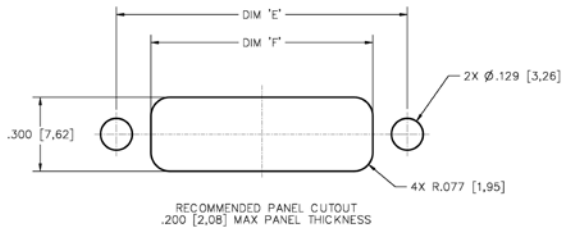

NUMBER OF BAYS	DIM 'E'	DIM 'F'	DIM 'G'
1 BAY	1,180 [29,97]	900 [22,86]	1,630 [41,40]
2 BAYS	1,580 [40,13]	1,300 [33,02]	2,030 [51,56]
3 BAYS	1,980 [50,29]	1,700 [43,18]	2,430 [61,72]
4 BAYS	2,380 [60,45]	2,100 [53,34]	2,830 [71,88]
5 BAYS	2,780 [70,61]	2,500 [63,50]	3,230 [82,04]

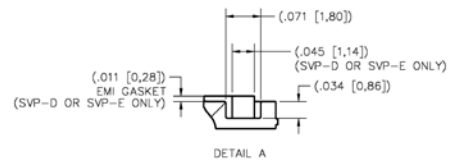
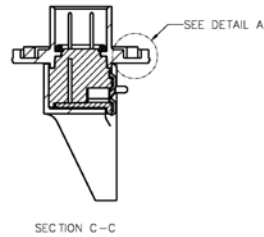
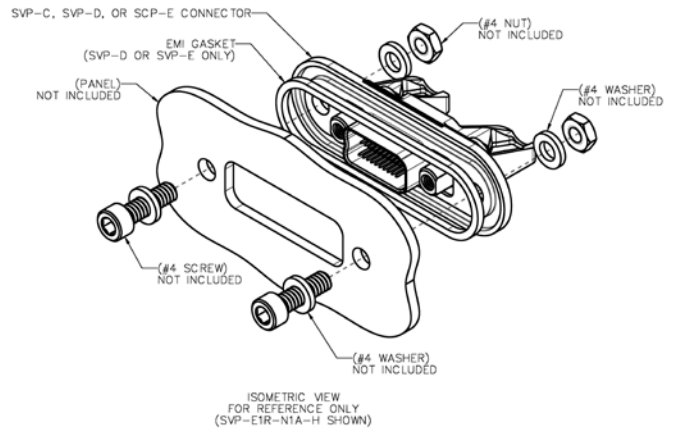

Please consult the AirBorn website for the latest revision of this document prior to beginning any design work.

All Modules		
Molded Insulators	Material	Glass-filled liquid crystal polymer (LCP)
Shells	Material	Zinc alloy 3 per SAE AMS4803 (AG40A) or aluminum alloy 6061-T6 per SAE AMS-4027 or 6061-T6511 per SAE AMS-QQ-A-200/8
	Finish	Electroless nickel, 500µ in min per SAE AMS2404, class 3
Hardware	Jack Post Material	Nitronic 60 per ASTM A193/A193M
	Jack Post Finish	Passivated per SAE AMS-2700
	Remaining Hardware Material	Stainless steel per ASTM A484/A484M, ASTM A582/A582M, or ASTM A320
	Remaining Hardware Finish	Passivated per SAE AMS-2700
Interfacial Seal	Material	Fluorosilicone elastomer per MIL-DTL-25988
Panel-Mount Gasket	Material	Conductive elastomer per MIL-DTL-83528, type D
HD Modules		
Pin Contact	Material	Phos bronze per ASTM B103
	Finish (Pin End)	50µ in min localized gold per ASTM B 488, type II, code C over 50µ in min nickel per ASTM B689, type 1
	Finish (Termination)	10-20µ in localized gold flash per ASTM B488 type I, code A or C over 50µ in min nickel per ASTM B689 type 1
Embedment	Material	Frey Eng. Co. Insulating compound CF3003-80 or equivalent
RF Modules		
RF Contact	Material (Pin & Socket)	BeCu per ASTM B196
	Material (Bushings)	Brass per JIS-C3604
	Material (Dielectric)	PTFE (white) per ASTM D1710
	Finish (Pin & Socket)	30µ in min localized gold over 100µ in min nickel per MIL-G-45204 type 1, class 4
	Finish (Bushing & Center Termination)	10µ in min localized gold over 100µ in min nickel per MIL-G-45204 type 1, class 2
	Finish (Dielectric)	N/A

Please consult the AirBorn website for the latest revision of this document prior to beginning any design work.

Dimensions

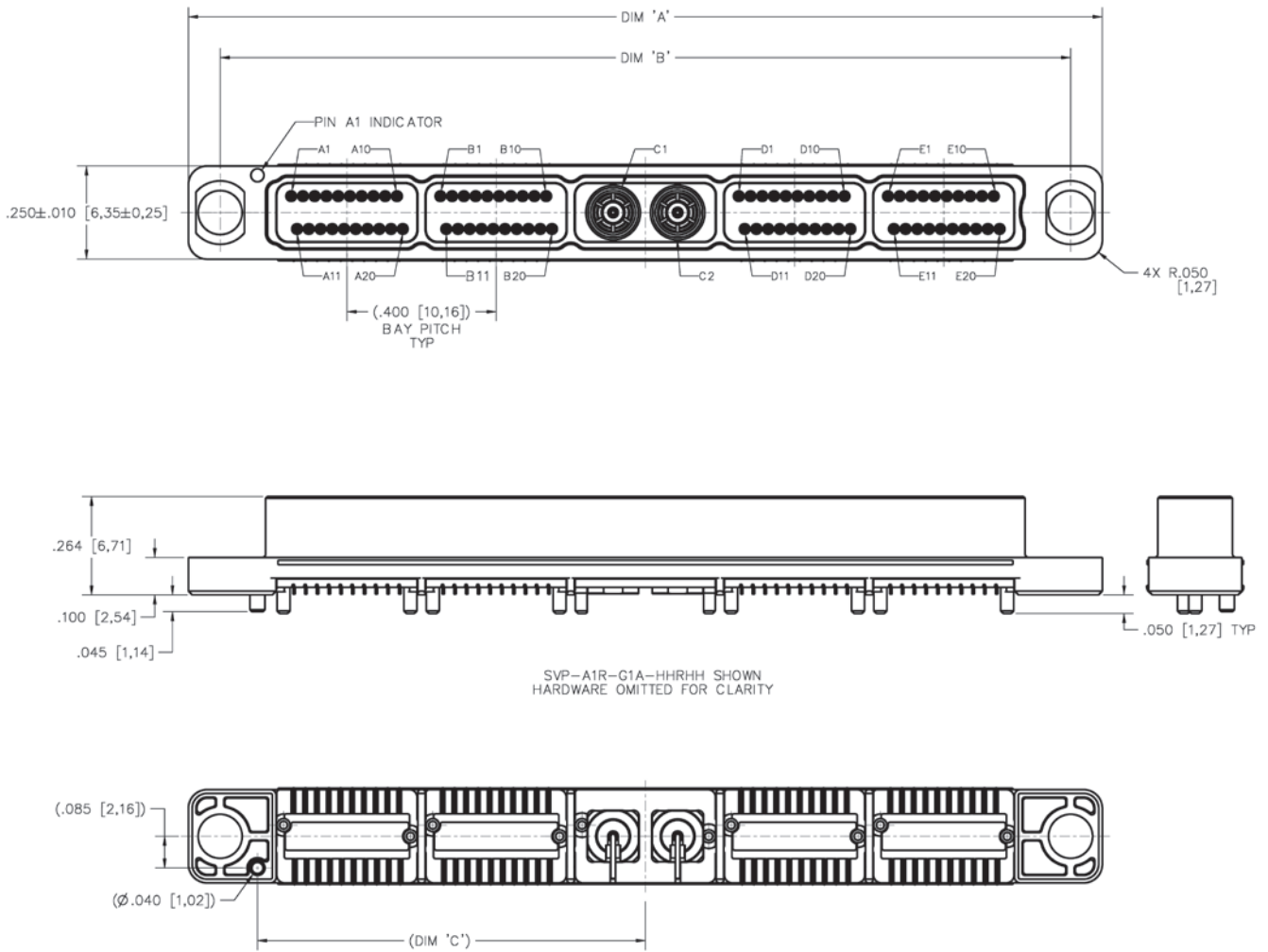

NUMBER OF BAYS	DIM 'A'	DIM 'B'	DIM 'C'
1 BAY	.850 [21,59]	.680 [17,27]	.240 [6,10]
2 BAYS	1.250 [31,75]	1.080 [27,43]	.440 [11,18]
3 BAYS	1.650 [41,91]	1.480 [37,59]	.640 [16,26]
4 BAYS	2.050 [52,07]	1.880 [47,75]	.840 [21,34]
5 BAYS	2.450 [62,23]	2.280 [57,91]	1.040 [26,42]

Please consult the AirBorn website for the latest revision of this document prior to beginning any design work.

SVP Panel Mounting Instructions

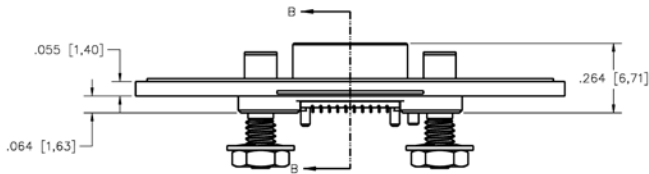
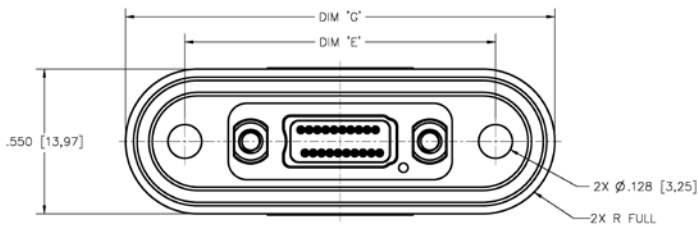
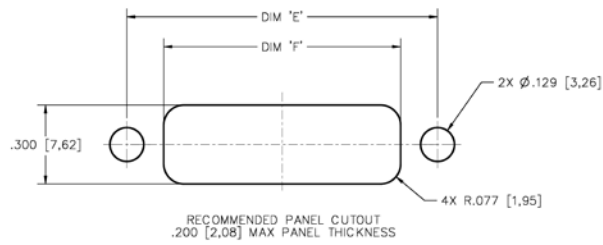

NUMBER OF BAYS	DIM 'E'	DIM 'F'	DIM 'G'
1 BAY	1,180 [29,97]	.900 [22,86]	1,630 [41,40]
2 BAYS	1,580 [40,13]	1,300 [33,02]	2,030 [51,56]
3 BAYS	1,980 [50,29]	1,700 [43,18]	2,430 [61,72]
4 BAYS	2,380 [60,45]	2,100 [53,34]	2,830 [71,88]
5 BAYS	2,780 [70,61]	2,500 [63,50]	3,230 [82,04]

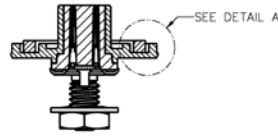
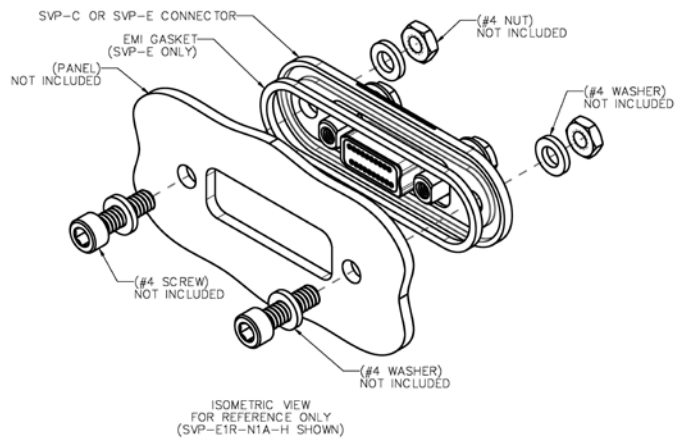

SECTION B-B

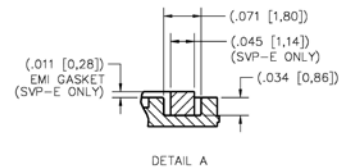

Please consult the AirBorn website for the latest revision of this document prior to beginning any design work.

All Modules		
Molded Insulators	Material	Glass-filled liquid crystal polymer (LCP)
Shells	Material	Zinc alloy 3 per SAE AMS4803 (AG40A) or aluminum alloy 6061-T6 per SAE AMS-4027 or 6061-T6511 per SAE AMS-QQ-A-200/8
	Finish	Electroless nickel, 500µ in min per SAE AMS2404, class 3
Hardware	Washer Material	Stainless steel per SAE NASM35333 (ASTM A240)
	Washer Finish	Passivated per SAE NASM35333 (SAE AMS-2700)
	Jack Post Material	Nitronic 60 per ASTM A193/A193M
	Jack Post Finish	Passivated per SAE AMS-2700
	Remaining Hardware Material	Stainless steel per ASTM A484/A484M, ASTM A582/A582M, or ASTM A320
	Remaining Hardware Finish	Passivated per SAE AMS-2700
Panel-Mount Gasket	Material	Conductive elastomer per MIL-DTL-83528, type D
HD Modules		
Pin Contact	Material	Phos bronze per ASTM B103
	Finish (Pin End)	50µ in min localized gold per ASTM B 488, type II, code C over 50µ in min nickel per ASTM B689, type 1
	Finish (Termination)	10-20µ in localized gold flash per ASTM B488 type I, code A or C over 50µ in min nickel per ASTM B689 type 1
Embedment	Material	Frey Eng. Co. Insulating compound CF3003-80 or equivalent
RF Modules		
RF Contact	Material (Pin & Socket)	BeCu per ASTM B196
	Material (Bushings)	Brass per JIS-C3604
	Material (Dielectric)	PTFE (white) per ASTM D1710
	Finish (Pin & Socket)	30µ in min localized gold over 100µ in min nickel per MIL-G-45204 type 1, class 4
	Finish (Bushing & Center Termination)	10µ in min localized gold over 100µ in min nickel per MIL-G-45204 type 1, class 2
	Finish (Dielectric)	N/A

Please consult the AirBorn website for the latest revision of this document prior to beginning any design work.

Dimensions

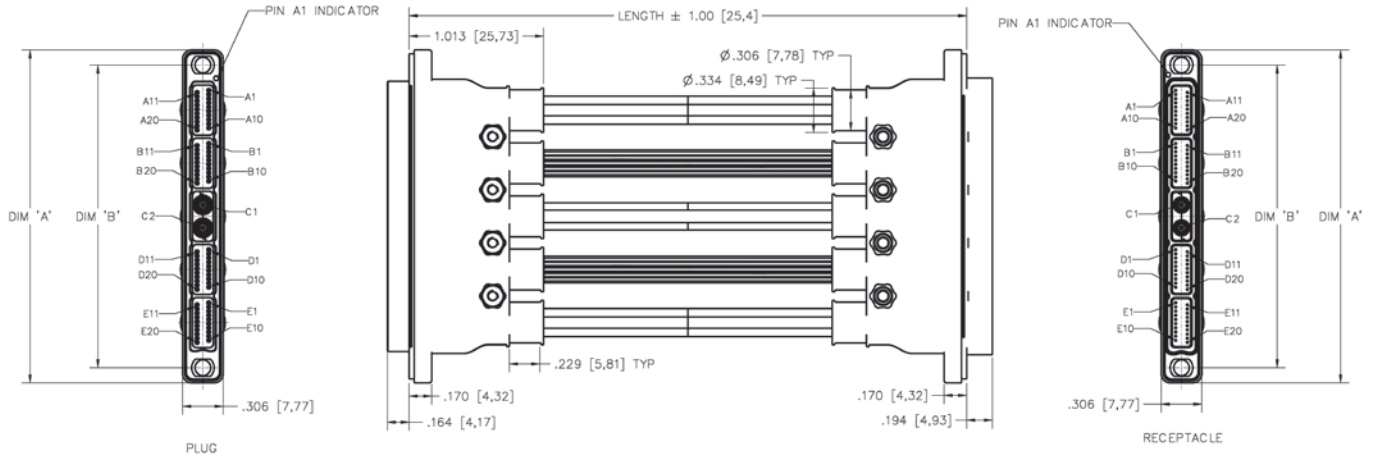

MATING FACE ORIENTATION

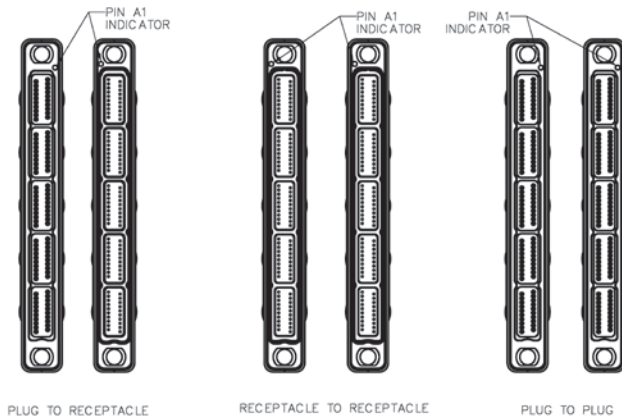

NUMBER OF BAYS	DIM 'A'	DIM 'B'
1 BAY	.908 [23,06]	.680 [17,27]
2 BAYS	1.308 [33,22]	1.080 [27,43]
3 BAYS	1.708 [43,38]	1.480 [37,59]
4 BAYS	2.108 [53,54]	1.880 [47,75]
5 BAYS	2.508 [63,70]	2.280 [57,91]

CODE	LENGTH*	
	LENGTH (M)	LENGTH (IN)
010	0.10	3.94±.50
020	0.20	7.87±.50
030	0.30	11.81±.50
040	0.40	15.75±1.00
050	0.50	19.69±1.00
060	0.60	23.62±1.00
070	0.70	27.56±1.00
080	0.80	31.50±1.00
090	0.90	35.43±1.00
100	1.00	39.37±2.00
150	1.50	59.06±2.00
200	2.00	78.74±2.00
300	3.00	118.11±2.00

*CUSTOM LENGTHS AVAILABLE UPON REQUEST

Please consult the AirBorn website for the latest revision of this document prior to beginning any design work.

SC Panel Mounting Instructions

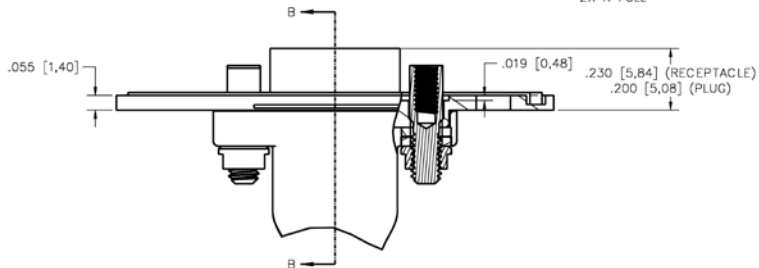
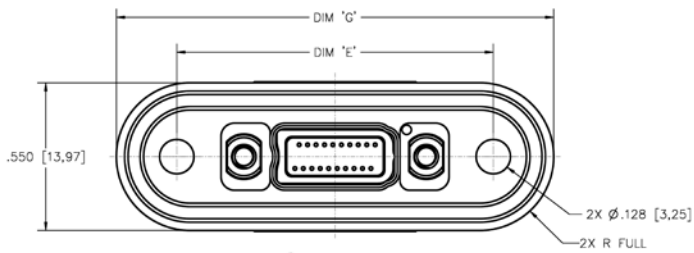
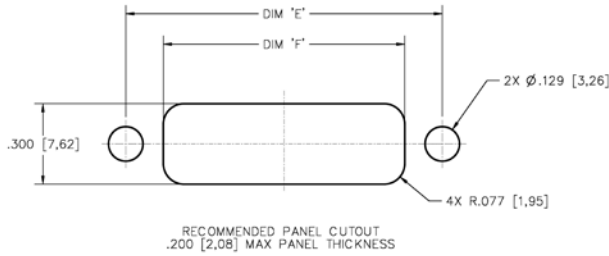

NUMBER OF BAYS	DIM 'E'	DIM 'F'	DIM 'G'
1 BAY	1.180 [29,97]	.900 [22,86]	1.630 [41,40]
2 BAYS	1.580 [40,13]	1.300 [33,02]	2.030 [51,56]
3 BAYS	1.980 [50,29]	1.700 [43,18]	2.430 [61,72]
4 BAYS	2.380 [60,45]	2.100 [53,34]	2.830 [71,88]
5 BAYS	2.780 [70,61]	2.500 [63,50]	3.230 [82,04]

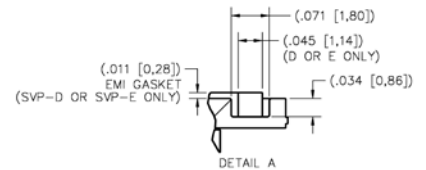
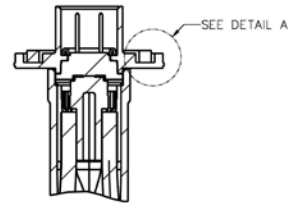
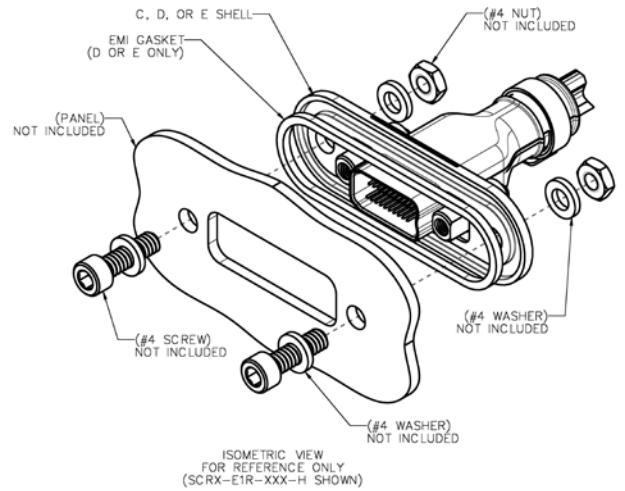

Please consult the AirBorn website for the latest revision of this document prior to beginning any design work.

SC Materials & Finishes

All Modules		
Molded Insulators	Material	Glass-filled liquid crystal polymer (LCP)
Shells	Material	Zinc alloy 3 per SAE AMS4803 (AG40A) or aluminum alloy 6061-T6 per SAE AMS-4027 or 6061-T6511 per SAE AMS-QQ-A-200/8
	Finish	Electroless nickel, 500μ in min per SAE AMS2404, class 3
Hardware	Socket Head Cap Screw Material	Stainless steel per NAS1352
	Socket Head Cap Screw Finish	Passivated per NAS13
	Jack Post Material	Nitronic 60 per ASTM A193/A193M
	Jack Post Finish	Passivated per SAE AMS-2700
	Remaining Hardware Material	Stainless steel per ASTM A484/A484M, ASTM A582/A582M, or ASTM A320
	Remaining Hardware Finish	Passivated per SAE AMS-2700
Band Clamp (Single Bay Only)	Material	Stainless steel per TBD
	Finish	Passivated per AMS2700
Solder	Material	SAC305, 95.5% Sn, 3.0% Ag, .5% Cu
Overmold	Material	TBD
Interfacial Gasket	Material	Fluorosilicone elastomer per MIL-DTL-25988
Panel-Mount Gasket	Material	Conductive elastomer per MIL-DTL-83528, type D
Twinax and Discrete Wire Modules		
Contact	Pin Material	Phos bronze per ASTM B103
	Socket Material	BeCu Per ASTM B194
	Finish (Mating End)	50μ in min localized gold per ASTM B 488, type II, code C over 50μ in min nickel per ASTM B689, type 1
Twinax/Discrete Wire		See product spec. drawing SCXX-XXX-XXX-XXX-XXXXX
RF Module		
RF Contact	Material (Pin & Socket)	BeCu per ASTM B196
	Material (Bushings)	Brass per JIS-C3604
	Material (Dielectric)	PTFE (white) per ASTM D1710
	Finish (Pin & Socket)	30μ in min localized gold over 100μ in min nickel per MIL-G-45204 type 1, class 4
	Finish (Brushing & Center Termination)	10μ in min localized gold over 100μ in min nickel per MIL-G-45204 type 1, class 2
	Finish (Dielectric)	N/A
Coaxial Cable		See product spec. drawing SCXX-XXX-XXX-XXX-XXXXX

Please consult the AirBorn website for the latest revision of this document prior to beginning any design work.

The AirBorn Advantage

Model-To-Market Solutions



Custom Power Systems



VPX Power Supply

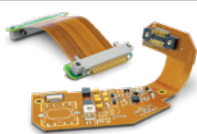

Flexible Circuit Assemblies



Cable Assemblies



FUZE Assemblies



Active Optical Assemblies



Rectangular W Series



Rectangular R Series



Micro D M Series



Nano D N Series



High-Speed Rectangular verSI



Modular Hybrid Snergy



Macro D Rocket

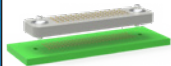

Z Axis Interposer Z Series



High-Speed Micro D microSI

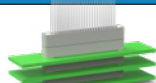

Stackable RC Series



Circulars Series 360



Strip Connector AirStrip



PowerAmp 13A or 23A



Rugged Circulars TriMate

SGYC-2.25

AirBorn
a **molex** company

p. 512.863.5585
www.airborn.com

