



**FREQUENCY
CONTROLS**

Powered By **ABRACON**



Crystal Oscillator Based Clean-Up Modules

The Challenges

Modern electronic equipment, like Radar, Test and Measurement, Instrumentation, Avionics, etc. require precision frequency sources with low phase noises. Frequency accuracy and precision can derive from atomic clocks (such as Rubidium or Cesium) or GNSS. In many cases, however, frequency accuracy and precision does not necessarily accompany low phase noise. Similar problems occur when the clock signals distribute over long distances through noisy environments.

One example of precision atomic clock based sources with poor phase noise performance is a Chip Scale Atomic Clock (CSAC). Typical examples of phase noise performance on a 10 MHz output are shown in Table 1.

Table 1—Phase Noise Performance on a 10 Mhz Output

Phase Noise, dBc/Hz	Manufacturer			
	Microchip	Teledyne	Accubeat	Spectratime
@1 Hz,	-50	-56	—	-65
@10 Hz	-70	-80	-86	-90
@100 Hz	-113	-113	-120	-110
@1 KHz	-128	-130	-138	-135
@10 KHz	-135	-140	-148	-140
@100 KHz	-140	-142	-150	-140

For many applications, such phase noise performance is not acceptable.

The Solutions

The goal is to maintain accuracy, precision and long-term stability of the source, while significantly improving the phase noise of the signal. Achieving this goal is accomplished through so called Clean-Up Modules, based on different types of Quartz Crystal Oscillators.

Here are two possible scenarios:

1. The source is based on GNSS. In this case, there's the potential to lose the satellite signal. Therefore, the module must provide good accuracy and stability in the absence of the reference signal, during the so-called holdover. The module would need to be based on either an OCXO or high performance TCXO.
2. The source is based on Atomic clock. In this case, if the source signal is lost, it is most likely lost forever. No holdover is required. A VCXO based module is sufficient in this situation.

How It's Done

The basis for the clean-up is a high performance (Low or Ultra-Low Phase Noise) Quartz Crystal Oscillator with Voltage Control function, which is locked to the incoming accurate, but noisy signal via PLL. A simplified block diagram of a typical clean-up module is shown on Fig. 1.

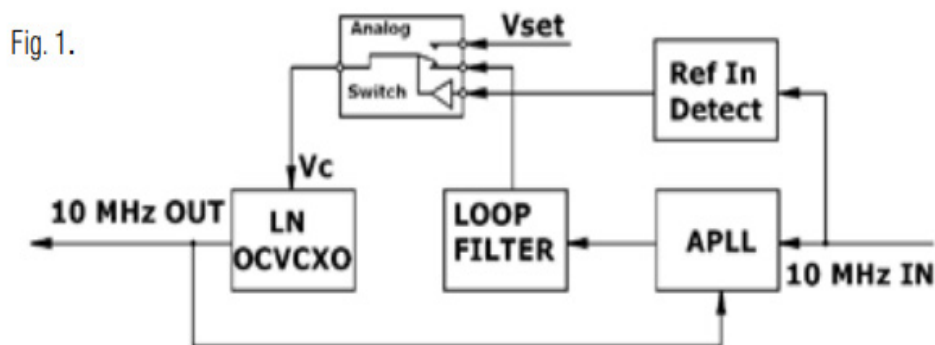

Instead of using the OCVCXO, depending on the application, one could use a TCVCXO or VCXO.

NEL Frequency Controls offers a family of Clean-Up Modules from very compact VCXO-based SMD units, to TCVCXO based units with good holdover performance, to Ultra-Low Phase Noise (ULPN) OCVCXO based metal can modules and rack mountable appliances.

The modules provide phase noise performance improvement of up to 50 dB. An example of a phase noise improvement for an OCVCXO based module with a bench top Rubidium Clock input is shown on Fig. 2.

Fig. 2.

